

Engineering Manual & Buyers Guide

Experience Counts

LINK-SEAL® MODULAR SEALS | CENTURY-LINE® SLEEVES | CELL-CAST® DISKS

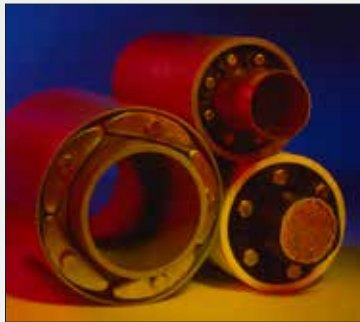

40 years and still sealing



Experience Counts - Use the Original



Table of Contents

LINK-SEAL® MODULAR SEALS

The System is the Solution 4

Applications..... 4

Features..... 5

Model Options - Material Properties 6-9

Dimensional Data..... 10

Sizing Procedure - Method 1..... 11-15

Sizing Procedure - Method 2..... 16

Suggested O.D. Pipe Ranges 17

Sizing Procedure - Method 2 (Verification)..... 18-23

CENTURY-LINE® SLEEVES

Features..... 24

Weights and Dimensional Data..... 24

CELL-CAST® DISKS

Features..... 25

Weights and Dimensional Data..... 25

TYPE WS STEEL WALL SLEEVES

Weights, Dimensional Data and Specifications 26

TECHNICAL/ENGINEERING

LINK-SEAL® Modular Seal Bolt Test Results..... 9

LINK-SEAL® MODULAR SEALS - SPECIALTY APPLICATIONS

Steel Pipe Reference Schedules..... 27

Fire Seals 28

Sealing Pipeline Casings 29

Sealing An Oversize Annulus..... 30

Pressure Testing 30

Sealing Manhole Penetrations 31

INSTALLATION TECHNIQUES

LINK-SEAL® Modular Seal Installation 32-33

CENTURY-LINE® Sleeve Installation..... 34

CELL-CAST® Disk Installation..... 35

Product Ordering Code..... 36

Typical Specification..... 37

Frequently Asked Questions 38-39

Technical Approvals 40

Performance data included in this manual is intended for guideline purposes only. Performance suitability for any specific application should be determined by the end user. Variation in temperature, pressure, concentration or mixtures acting synergistically may preclude recommended service use.

CAD drawings (.dwg) are available on-line. Drawings can be downloaded and inserted into Auto-CAD for drawing plans. Submittal sheets can also be accessed in a PDF file. Contact GPT or your local authorized distributor for support and purchasing information.

LINK-SEAL® MODULAR SEALS WITH CAST OR CORE DRILLED WALL OPENING MANUFACTURED BY GPT, HOUSTON, TEXAS, U.S.A.
TELEPHONE: 800.423.2410. EMAIL: INFO@GPTINDUSTRIES.COM

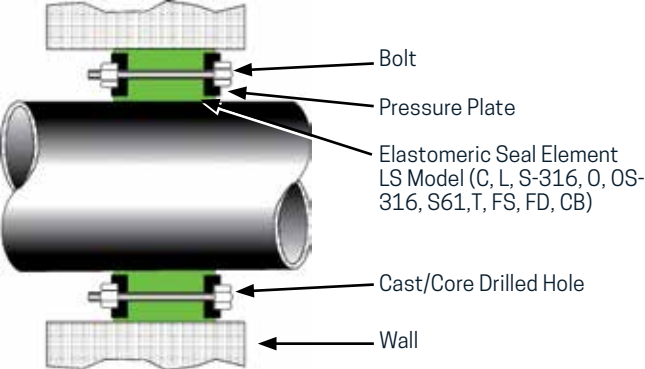

LINK-SEAL® MODULAR SEALS WITH MODEL WS STEEL WALL SLEEVES MANUFACTURED BY GPT, HOUSTON, TEXAS, U.S.A.
TELEPHONE: 800.423.2410. EMAIL: INFO@GPTINDUSTRIES.COM

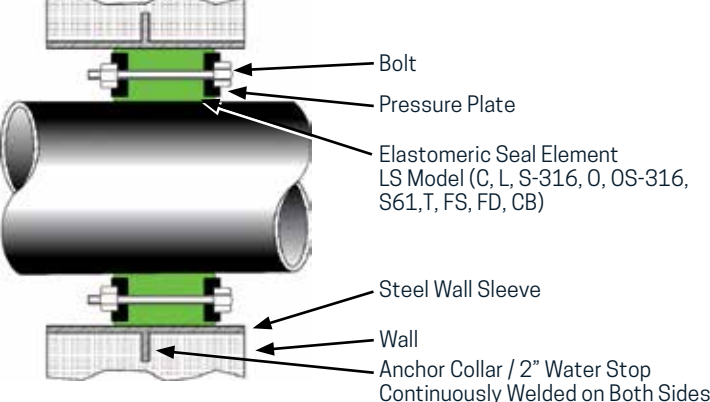

LINK-SEAL® MODULAR SEALS WITH CENTURY-LINE® SLEEVES MANUFACTURED BY GPT, HOUSTON, TEXAS, U.S.A.
TELEPHONE: 800.423.2410. EMAIL: INFO@GPTINDUSTRIES.COM

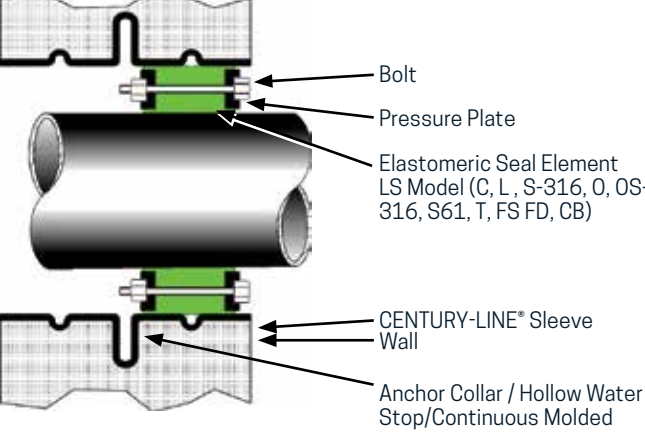

The System is the Solution

LINK-SEAL® MODULAR SEALS

The best way to permanently seal any cylindrical object, of any size, passing through any type of concrete barrier (wall, floor or ceiling) is to use LINK-SEAL® modular seals. From ductile iron to pre-stressed concrete to metal or plastic pipe, conduit or cables - whatever your application - LINK-SEAL® modular seals will affect a hydrostatic seal capable of holding 20 psig (40 feet of static head) between the pipe and the penetration cylinder through which the pipe passes.



IN COMBINATION WITH CENTURY-LINE® SLEEVES

The best way to guarantee a perfect seal is to use CENTURY-LINE® sleeves with LINK-SEAL® modular seals. They're engineered and sized to provide a stable hole that matches dimensionally with LINK-SEAL® modular seals. It makes ordering quick and easy and guarantees a perfect fit - and seal - each and every time.



CELL-CAST® DISKS

For larger holes in poured concrete structures, (29.25" to 64.75"Ø) CELL-CAST® disks are used to produce a dimensionally stable hole and smooth concrete surface that is perfect for use with LINK-SEAL® modular seals.



LINK-SEAL® Modular Seal Applications

- » Mechanical Contractors - Interior & Exterior Piping Systems
- » Manhole Pipe Entry Seals
- » Waste Treatment Plants
- » Cased Road Crossings
- » Thermal Storage Systems
- » Fire Protection Wall Penetrations
- » Cased Railroad Crossings
- » Electrical Isolation of Pipes
- » Precast Concrete Vault Seals
- » Insulated Pipe Seals
- » Dual Containment Seals
- » Marine Applications
- » Noise Dampening
- » Flexible Sign & Pole Supports
- » Electrical Isolation of Pipe Supports
- » Mining
- » Pulp & Paper
- » Decorative Fountains
- » Pool Contractors
- » Electrical Contractors
- » Waste Water & Water Treatment Plants
- » Telecommunications
- » Valve Pits
- » Refrigeration Buildings
- » Guard Post Assemblies
- » Power Generation Dams
- » Offshore Oil Rigs
- » High Pressure Tank Guards
- » Underground Steel Tanks
- » Precast Concrete Manufacturers
- » Perimeter Berm Installations Around Tank Farms
- » Flow Restrictions in Sewer Maintenance
- » Fluid Overflow Devices
- » Noise and Sway Dampener
- » Through Deck Fire Breaks
- » Bridge Construction
- » Septic Tank Installations
- » Coal Preparation Plants
- » Tunneling Operations

LINK-SEAL® Modular Seal Features

SAVES TIME AND MONEY

LINK-SEAL® modular seals install in up to 75% less time when compared to lead-oakum joints, hand fitted flashings, mastics or casing boots.

POSITIVE HYDROSTATIC SEAL

LINK-SEAL® modular seals are rated at 20 psig (40 feet of head), which exceeds the performance requirements of most applications.

LONG SEAL LIFE

LINK-SEAL® modular seals are designed for use as a permanent seal. Seal elements are specially compounded to resist aging and attack from ozone, sunlight, water and a wide range of chemicals.

MAXIMUM PROTECTION AGAINST CORROSION

Fasteners employ the use of a proprietary coating process on carbon steel. For extremely corrosive environments, corrosion resistant 316 stainless steel hardware is offered as a standard.

ISO QUALITY ASSURANCE

LINK-SEAL® modular seals are manufactured and assembled in an ISO 9001:2008 certified facility in the U.S.A.

CERTIFICATION/APPROVALS

Factory Mutual Approval, Det Norske Veritas Marine Deak/Bulkhead Penetration Certification. Also a wide variety of approvals from various Federal agencies, associations, code groups, laboratories and organizations.

CONFIGURE A LINK-SEAL® MODULAR SEAL TO MATCH YOUR APPLICATION

Color coded EPDM, Nitrile, & Silicone elastomers may be used with various hardware options to match performance characteristics with service conditions.

CHOOSE A LINK-SEAL® MODULAR SEAL TO MATCH YOUR PIPE SIZE AND WALL OPENING

LINK-SEAL® modular seals are now available in 16 sizes to provide a solution for varying pipe penetration applications.



LINK-SEAL® Sizing Method

LINK-SEAL® Modular Seal sizing is the preferred method designed to put the most rubber in the annular space. This updated method benefits the engineer, owner and contractor.

FEATURES: More Rubber in Annular Space = Better Performing Seal

- » Engineered fit
- » Increased vibration dampening
- » Minimum loads on bolts and pressure plates with same sealing effect
- » Most sealing pressure/most volume of sealing element in penetration
- » Curvature of link sized to penetration O.D. and I.D. for smooth fit

In accomplishing putting more rubber in the annular space, the LINK-SEAL® assembly may require a larger size link with less links per belt or a smaller size link with more links per belt. The difference between Sleeve and Cored Hole sizing has also been taken into consideration.

LINK-SEAL® Modular Seal Model Properties

WITH EPDM SEAL ELEMENTS



EPDM (Black)

* = Sustained operation near temperature limits may affect life expectancy.

Model "C" LINK-SEAL® Modular Seal

Suitable for direct ground burial, normal atmospheric conditions, and conditions with occasional or periodic water contact. Provides electrical isolation where cathodic protection is required.

Type: Standard

Seal Element: EPDM (Black)

Pressure Plates: Reinforced Nylon Polymer

Bolts & Nuts: Steel with 2-part Zinc Dichromate & proprietary corrosion inhibiting coating.

Temp. Range: -40° - +250°F (-40° - +121°C)*

Model "S-316" LINK-SEAL® Modular Seal

For chemical processing & waste water treatment. High level of water-resistance, resistant to most inorganic acids and alkalis, and most organic chemicals (acetone, alcohol, ketones).

Type: Stainless

Seal Element: EPDM (Black)

Pressure Plates: Reinforced Nylon Polymer

Bolts & Nuts: 316 Stainless Steel

Temp. Range: -40° - +250°F (-40° - +121°C)*

WITH EPDM SEAL ELEMENTS



EPDM (Blue) Low Durometer

* = Sustained operation near temperature limits may affect life expectancy.

Model "L" LINK-SEAL® Modular Seal

Low Durometer EPDM specifically designed for use with fragile pipe and tubing. Suitable for direct ground burial, normal atmospheric conditions, and conditions with occasional or periodic water contact. Provides electrical isolation where cathodic protection is required

Type: Standard

Seal Element: EPDM (Blue)

Pressure Plates: Reinforced Nylon Polymer

Bolts & Nuts: Steel with 2-part Zinc Dichromate & proprietary corrosion inhibiting coating.

Temp. Range: -40° - +250°F (-40° - +121°C)*

Model "LS-316" LINK-SEAL® Modular Seal

Low Durometer EPDM specifically designed for use with fragile pipe and tubing. For chemical processing & waste water treatment. High level of water-resistance, resistant to most inorganic acids and alkalis, and most organic chemicals (acetone, alcohol, ketones).

Type: Stainless

Seal Element: EPDM (Blue)

Pressure Plates: Reinforced Nylon Polymer

Bolts & Nuts: 316 Stainless Steel

Temp. Range: -40° - +250°F (-40° - +121°C)*

WITH NITRILE SEAL ELEMENTS



Nitrile (Green)

* = Sustained operation near temperature limits may affect life expectancy.

Model "O" LINK-SEAL® Modular Seal

Nitrile rubber is resistant to oils, fuel and many solvents (gasoline, motor oil, kerosene, methane, jet fuel, hydraulic fluid, water, etc.)

Type: Oil Resistant

Seal Element: Nitrile (Green)

NOTE: Not U.V. resistant

Pressure Plates: Reinforced Nylon Polymer

Bolts & Nuts: Steel with 2-part Zinc Dichromate & proprietary corrosion inhibiting coating

Temp. Range: -40° - +210°F (-40° - +99°C)*

Model "OS-316" LINK-SEAL® Modular Seal

Combination of oil resistant rubber and stainless steel hardware

Type: Oil Resistant

Seal Element: Nitrile (Green)

NOTE: Not U.V. resistant

Pressure Plates: Reinforced Nylon Polymer

Bolts & Nuts: 316 Stainless Steel

Temp. Range: -40° - +210°F (-40° - +99°C)*

LINK-SEAL® Modular Seal Model Properties

WITH SILICONE SEAL ELEMENTS



Silicone (Grey)

* = Sustained operation near temperature limits may affect life expectancy.

NOTE: Sustains a constant temp. of 325°F (163°C)

For more detailed information on this product please refer to page 28

Model “T” LINK-SEAL® Modular Seal

Silicone rubber is ideal for temperature extremes. The “T” model is one-hour Factory Mutual approved.

Type: High/Low Temperature

Seal Element: Silicone (Grey)

Pressure Plates: Steel Zinc Dichromate

Bolts: Steel with 2-part Zinc Dichromate & proprietary corrosion inhibiting coating.

Temp. Range: -67° - +400°F (-55° - +204°C)*

Models “FD & FS” LINK-SEAL® Modular Seal

Double seal for added protection

Type: Fire Seals

Seal Element: Silicone (Grey)

Pressure Plates: Steel zinc dichromate

Bolts: Steel with 2-part Zinc Dichromate & proprietary corrosion inhibiting coating.

Temp. Range: -67° - +400°F (-55° - +204°C)*

LINK-SEAL® NSF Certified Product

WITH NDF 61 EPDM SEAL ELEMENTS



EPDM (Black)

* = Sustained operation near temperature limits may affect life expectancy.

The Model “S61” is made from Black NSF 61 certified EPDM materials, with Blue reinforced Nylon Polymer Pressure plates and 316 Stainless Steel hardware. Each shipment is packaged with a defining “NSF 61” label and batch number for traceability.

Model “S61” LINK-SEAL® Modular Seal

NSF 61 Certified for use in potable water (drinking water)

Type: Stainless

Seal Element: EPDM (Black)

Pressure Plates: Blue Reinforced Nylon Polymer

Bolts & Nuts: 316 Stainless Steel

Temp. Range: -40° - +250°F (-40° - +121°C)*



NSF Certificate # C0162325-01

SPECIFICATIONS:

- » Type: Potable water
- » Seal Element: Black EPDM NSF 61 Certified
- » Pressure Plates: Blue Reinforced Nylon Polymer
- » Bolts & Nuts: 316 Stainless Steel
- » Temperature Range: -40°F to 250°F (-40°C to 121°C)
- » Certified to NSF/ANSI Standard 61

IDEAL FOR:

- » Hospital lines
- » Laboratories
- » Water treatment plants
- » Processes where purity is important
- » All potable water applications
- » Process water for manufacturing operations
- » Food service
- » Food OEM's
- » Sanitary milk service
- » Food transportation
- » Reservoir
- » Pumping Stations





LINK-SEAL® Modular Seal Model Properties

MATERIAL PROPERTIES OF LINK-SEAL® MODULAR SEAL ELEMENTS

Property	ASTM Method	EPDM (EPDM L)	Nitrile	Silicone
Hardness (shore A)	D-2240	50 ±5 (40 ±5)	50 ±5	50 ±5
Tensile	D-412	1450 psi	1300 psi	860 psi
Elongation	D-412	400%	300%	250%
Compression Set	S-395	15% 22 hrs. @ 158° F (70° C)	45% 22 hrs. @ 212° F (100° C)	40% 22 hrs. @ 350° F (177° C)
Specific Gravity	D-297	1.10	1.15	1.40

MATERIAL PROPERTIES OF COMPOSITE PRESSURE PLATES

Property	ASTM Method	Value
Izod Impact - Notched	D-256	1.11 ft-lb/in
Tensile Strength @ Yield	D-638	20,000 psi
Tensile Strength - Break	D-638	20,250 psi
Flexural Strength @ Yield	D-790	30,750 psi
Flexural Modulus	D-790	1,124,000 psi
Elongation, Break	D-638	11.07%
Specific Gravity	D-792	1.38
Moisture Content	--	0.18%

Link-Seal® Model	Tool Size/ Type Req.	Bolt Head Type
LS-200, LS-275	4mm, Allen	
LS-300, LS-315	6mm, Allen	
LS-325, LS-340, LS-360	13mm, Hex	
LS-400, LS-410, LS-425, LS-475	17mm, Hex	
LS-500, LS-525, LS-575	19mm, Hex	
LS-615	24mm, Hex	
LS-650	19mm, Hex	

To provide consistency and worldwide compatibility, GPT now offers all LINK-SEAL® Modular Seal sizes with metric bolts. The new bolts adhere to metric specifications as used by most all countries outside the U.S.A. Smaller LINK-SEAL® Modular Seals (sizes LS-200, LS-275, LS-300, and LS-315) will consist of metric Allen head or socket cap bolt heads while the balance of the line will use standard hex head metric bolts.

LINK-SEAL® Modular Seal Model Properties

BOLT & NUT SPECIFICATION

Carbon Steel

Carbon steel, zinc dichromated per ASTM B633, with an additional corrosion inhibiting proprietary organic coating. (passes 1470 hour salt spray test)
Tensile Strength = 60,000 psi, minimum.

An independent 1,470 hour salt spray test run in accordance to ASTM B117-97 has proven LINK-SEAL® modular seals' Zinc Dichromated Carbon Steel bolts, with proprietary corrosion inhibiting coating, to be superior when compared with competitive manufactures.

Stainless Steel

ANSI Type = 316, Per ASTM F593-95
Tensile Strength = 85,000 psi, average



INDEPENDENT LABORATORY TEST

The Newly Engineered Force Dispersion Pressure Plates have been fully tested by an independent laboratory to ensure design theory translates into the capability to handle the rigors of real world applications.



In addition, the new design has an average of 15% more strength than previous LINK-SEAL® Modular Seal versions.



1,470 hour salt spray test run in accordance to ASTM B117-97 has proven LINK-SEAL® modular seals' Zinc Dichromated Carbon Steel bolts, with proprietary corrosion inhibiting coating, to be superior when compared with competitive manufactures. Test Results are available on request.

Dimensional Data

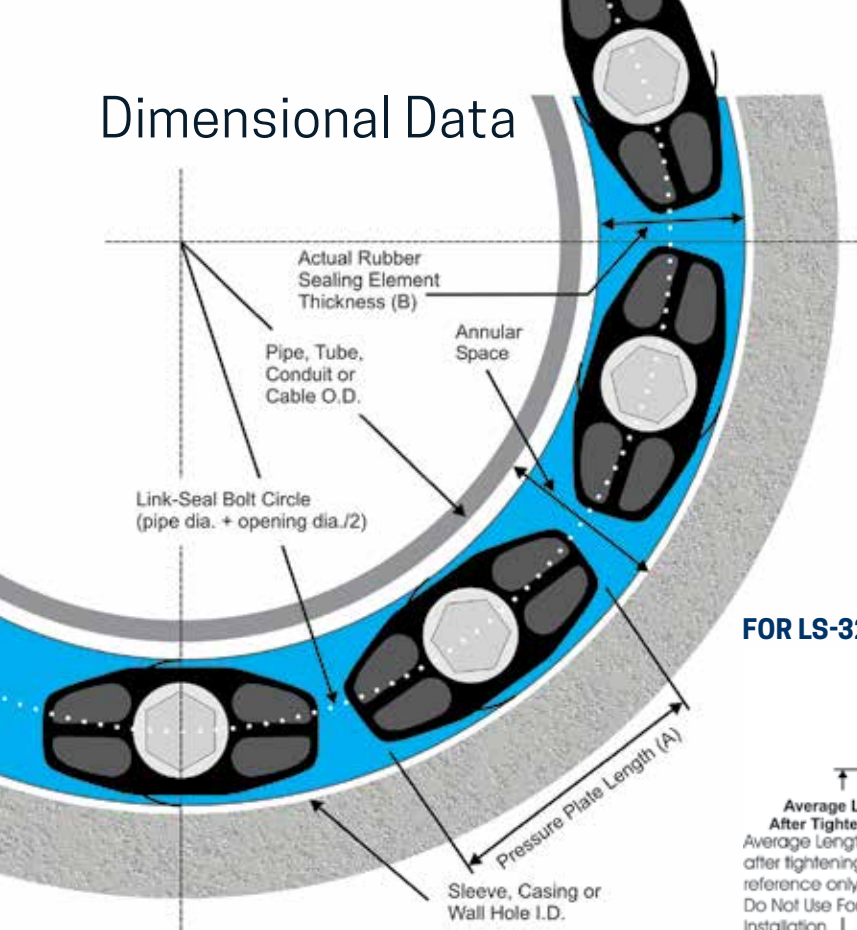

FOR LS-200 THROUGH LS-315

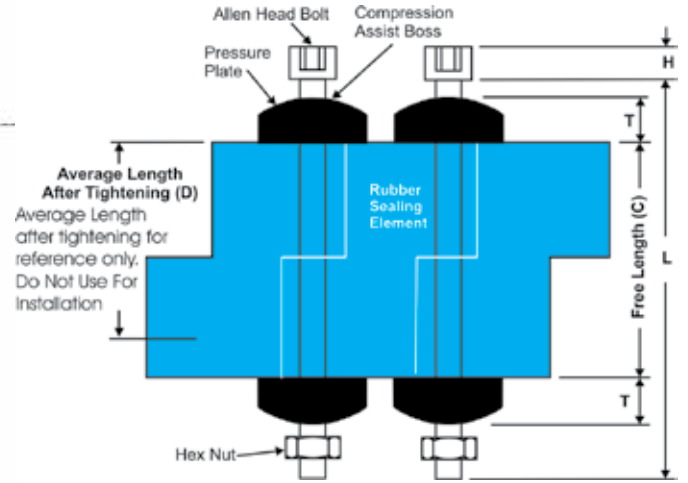

FOR LS-325 THROUGH LS-650

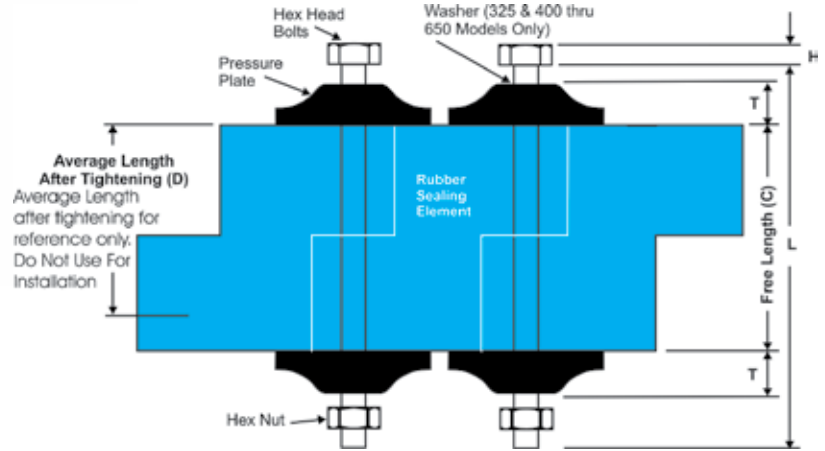

* DIMENSIONAL DATA FOR MODELS C, L, O, S-316, S61, LS-316 & OS-316

LINK-SEAL® Model No.	Rubber Sealing Elements			Pressure Plates		Bolts				Weight for 10 Link Sections (lbs)	Min. Required Seating Width
	Actual Thickness (B)	Free Length (C)	Avg. Length After Tightening (D)	(A)	(T)	Allen Head Hex Across Flats	(H)	Thread Size	(L)		
LS-200-*	0.48"	1.75"	1.38"	1.06"	0.31"	4mm Allen (0.157")	4.95mm (0.195")	M5-0.8	65mm (2.559")	0.70	2.25"
LS-275-*	0.61"	1.75"	1.38"	0.97"	0.31"	4mm Allen (0.157")	4.95mm (0.195")	M5-0.8	65mm (2.559")	0.75	2.25"
LS-300-*	0.69"	2.37"	1.87"	1.56"	0.44"	6mm Allen (0.236")	7.87mm (0.310")	M8-1.25	90mm (3.543")	2.15	3.00"
LS-315-*	0.81"	2.37"	1.87"	1.44"	0.44"	6mm Allen (0.236")	7.87mm (0.310")	M8-1.25	90mm (3.543")	2.30	3.00"
LS-325-*	0.88"	2.63"	2.00"	3.13"	1.00"	13mm (0.511")	5.30mm (0.215")	M8-1.25	110mm (4.33")	5.50	4.00"
LS-340-*	1.00"	2.70"	2.25"	1.48"	0.66"	13mm (0.511")	5.30mm (0.215")	M8-1.25	110mm (4.33")	3.30	4.00"
LS-360-*	1.24"	2.70"	2.25"	2.05"	0.77"	13mm (0.511")	5.30mm (0.215")	M8-1.25	110mm (4.33")	5.10	4.00"
LS-400-*	1.38"	3.50"	2.75"	3.50"	1.06"	17mm (0.669")	6.40mm (0.250")	M10-1.5	130mm (5.118")	12.00	5.00"
LS-410-*	1.43"	3.37"	2.87"	2.52"	0.88"	17mm (0.669")	6.40mm (0.250")	M10-1.5	130mm (5.118")	8.20	5.00"
LS-425-*	1.06"	3.00"	2.25"	3.50"	1.19"	17mm (0.669")	6.40mm (0.250")	M10-1.5	130mm (5.118")	10.00	5.00"
LS-475-*	1.56"	3.38"	2.63"	2.63"	0.88"	17mm (0.669")	6.40mm (0.250")	M10-1.5	130mm (5.118")	10.00	5.00"
LS-500-*	2.25"	3.75"	2.75"	3.63"	1.06"	19mm (0.748")	7.50mm (0.300")	M12-1.75	140mm (5.511")	22.50	5.00"
LS-525-*	2.06"	3.75"	2.87"	3.63"	1.06"	19mm (0.748")	7.50mm (0.300")	M12-1.75	140mm (5.511")	21.00	5.00"
LS-575-*	1.81"	3.75"	3.00"	3.00"	1.00"	19mm (0.748")	7.50mm (0.300")	M12-1.75	140mm (5.511")	15.50	5.00"
LS-615-*	3.09"	4.00"	3.00"	6.00"	1.90"	24mm (0.944")	10.57mm (0.416")	5/8-11	185mm (7.280")	60.60	6.00"
LS-650-*	2.71"	3.98"	3.00"	3.96"	1.19"	19mm (0.748")	7.50mm (0.300")	M12-1.75	140mm (5.511")	26.10	6.00"

Sizing Procedure - Method 1

LINK-SEAL® Modular Seals may be sized by using one or more methods.

Method 1 - Use the charts provided (Pages 11-15) for standard pipe sizes and types.

LINK-SEAL® Modular Seal Sizing Charts for Standard Pipe

HOW TO ORDER: USING THE PROVIDED SIZING CHARTS

1. Locate charts on pages 11-15 that corresponds to the type and size pipe being used
2. Verify that your pipe O.D. matches the actual outside diameter shown on the chart
3. Determine type of wall opening (CENTURY-LINE®, Steel Sleeve or Cast/Core Bit Drilled Hole)
4. Determine LINK-SEAL® Modular Seal model to be used (See information on pages 6-7)
5. To order LINK-SEAL® Modular Seals: under the appropriate wall opening column, LINK-SEAL® Modular Seal size (from SIZE column), LINK-SEAL® Modular Seal model *** (C, S-316, L, LS-316, LS-S61, O, OS-316, T or FD/FS from pages 6-7) and indicate number of links required per seal (from LINKS PER SEAL column). **[Example: LS-575-C-10]**
6. To order corresponding sleeves indicate model number (from MODEL NUMBER column), length of sleeve and quantity required. **[CENTURY-LINE® Example: CS-10-12"-1] [Steel Sleeve Example: WS-36-S-12"-1] [CELL-CAST® Example: CC-32-(3")2-(4")2]**
7. See Page 36 for detailed visual call-outs.



STEEL AND PLASTIC PIPE WITH SAME OUTSIDE DIAMETER (IPS)

Pipe Size (Nom.)	Actual O.D. (Inches)	CENTURY-LINE® SLEEVE			STEEL SLEEVE			CAST OR CORE BIT DRILLED HOLE		
		Model Number	LINK-SEAL® Size	Links Per Seal	Model Number	LINK-SEAL® Size	Links Per Seal	Hole I.D.	LINK-SEAL® Size	Links Per Seal
½	0.840	CS-2-*	LS-200-***	4	WS-2-15-S-*	LS-275-***	5	2.000	LS-200-***	4
¾	1.050	CS-3-*	LS-315-***	4	WS-2-½-20-S-*	LS-275-***	6	3.000	LS-315-***	4
1	1.315	CS-3-*	LS-300-***	4	WS-2-½-20-S-*	LS-200-***	5	3.000	LS-300-***	4
1¼	1.660	CS-3-*	LS-275-***	7	WS-3-21-S-*	LS-275-***	8	3.000	LS-275-***	8
1½	1.900	CS-3½-*	LS-275-***	8	WS-3-21-S-*	LS-200-***	7	4.000	LS-315-***	6
2	2.375	CS-4-*	LS-300-***	6	WS-3-½-22-S-*	LS-200-***	8	4.000	LS-300-***	6
2½	2.875	CS-4-*	LS-200-***	9	WS-4-23-S-*	LS-200-***	9	4.000	LS-200-***	9
3	3.500	CS-5-*	LS-300-***	8	WS-6-28-S-*	LS-360-***	7	5.000	LS-300-***	8
3½	4.000	CS-6-*	LS-340-***	10	WS-6-28-S-*	LS-340-***	9	6.000	LS-315-***	10
4	4.500	CS-6-*	LS-300-***	10	WS-6-28-S-*	LS-300-***	10	6.000	LS-300-***	10
5	5.563	CS-8-*	LS-360-***	10	WS-8-32-S-*	LS-340-***	13	8.000	LS-340-***	13
6	6.625	CS-10-*	LS-475-***	10	WS-10-36-S-*	LS-475-***	10	10.000	LS-475-***	10
8	8.625	CS-12-*	LS-475-***	12	WS-12-37-S-*	LS-475-***	12	12.000	LS-475-***	12
10	10.750	CS-14-*	LS-410-***	15	WS-14-37-S-*	LS-425-***	10	14.000	LS-475-***	14
12	12.750	CS-16-*	LS-475-***	17	WS-16-37-S-*	LS-425-***	12	16.000	LS-475-***	17
14	14.000	CS-16-*	LS-340-***	30	WS-18-37-S-*	LS-475-***	18	18.000	LS-575-***	16
16	16.000	CS-20-*	LS-410-***	21	WS-20-37-S-*	LS-475-***	21	20.000	LS-575-***	18
18	18.000	CS-22-*	LS-340-***	38	WS-22-37-S-*	LS-475-***	23	22.000	LS-575-***	20
20	20.000	CS-25-*	LS-500-***	18	WS-24-37-S-*	LS-475-***	25	24.000	LS-475-***	26
22	22.000	CS-25-*	LS-360-***	34	WS-26-37-S-*	LS-475-***	28	26.000	LS-575-***	24
24	24.000	CC-30-**	LS-500-***	21	WS-28-37-S-*	LS-475-***	30	28.000	LS-475-***	31
26	26.000	CC-30-**	LS-400-***	23	WS-30-37-S-*	LS-400-***	23	30.000	LS-575-***	28
28	28.000	CC-32-**	LS-400-***	25	WS-32-37-S-*	LS-400-***	25	32.000	LS-575-***	30
30	30.000	CC-36-**	LS-500-***	26	WS-34-37-S-*	LS-400-***	27	34.000	LS-575-***	32
32	32.000	CC-38-**	LS-500-***	28	WS-36-37-S-*	LS-400-***	29	36.000	LS-575-***	34
34	34.000	CC-38-**	LS-400-***	30	WS-40-37-S-*	LS-500-***	29	38.000	LS-575-***	36
36	36.000	CC-42-**	LS-500-***	31	WS-42-37-S-*	LS-500-***	31	40.000	LS-575-***	38
42	42.000	CC-48-**	LS-500-***	36	WS-48-37-S-*	LS-500-***	36	46.000	LS-575-***	44
48	48.000	CC-54-**	LS-500-***	40	WS-53-37-S-*	LS-525-***	40	52.000	LS-575-***	50

* = Specify sleeve length in inches ** = See CELL-CAST® Page 25 *** = Specify LS Model C, S-316, L...etc when ordering (Example LS-475-C-17) Technically there is no limit to the pipe size that can be sealed using LINK-SEAL® modular seals. Please contact factory for sizes not listed and for CS model plastic sleeves for walls less than 8" thick.

NOTE: Contact GPT (1-800-423-2410) or your local distributor if your pipe sizing solution is not listed in the provided charts



Sizing Procedure - Method 1



SDR-35 GRAVITY SEWER PIPE

Pipe Size (Nom.)	Actual O.D. (Inches)	CENTURY-LINE® SLEEVE			STEEL SLEEVE			CAST OR CORE BIT DRILLED HOLE		
		Model Number	LINK-SEAL® Size	Links Per Seal	Model Number	LINK-SEAL® Size	Links Per Seal	Hole I.D.	LINK-SEAL® Size	Links Per Seal
4	4.22	CS-6-*	LS-315-***	11	WS-6-28-S-*	LS-315-***	10	6.000	LS-315-***	10
6	6.28	CS-8-*	LS-315-***	15	WS-8-32-S-*	LS-315-***	15	8.000	LS-315-***	15
8	8.40	CS-10-*	LS-325-***	9	WS-10-36-S-*	LS-315-***	19	12.000	LS-475-***	12
10	10.50	CS-14-*	LS-475-***	14	WS-14-37-S-*	LS-360-***	17	14.000	LS-475-***	14
12	12.50	CS-18-*	LS-500-***	12	WS-16-37-S-*	LS-360-***	20	16.000	LS-475-***	17
15	15.30	CS-20-*	LS-475-***	20	WS-20-37-S-*	LS-575-***	17	18.000	LS-360-***	24
18	18.70	CS-24-*	LS-575-***	21	WS-22-37-S-*	LS-360-***	29	22.000	LS-475-***	24
21	22.05	CC-30-**	LS-615-***	13	WS-26-37-S-*	LS-475-***	28	26.000	LS-575-***	24
24	24.80	CC-30-**	LS-525-***	21	WS-28-37-S-*	LS-425-***	22	28.000	LS-475-***	31
27	27.95	CC-32-**	LS-400-***	25	WS-32-37-S-*	LS-400-***	25	32.000	LS-575-***	30
30	32.00	CC-38-**	LS-500-***	28	WS-36-37-S-*	LS-400-***	29	36.000	LS-575-***	34

= Specify sleeve length in inches ** = See CELL-CAST® Page 25 *** = Specify LS Model C, S-316, L...etc when ordering (Example LS-475-C-17)

DUCTILE IRON PIPE (DIPS, AWWA-C900, AWWA-C905, PVC WATER PIPE)

Pipe Size (Nom.)	Actual O.D. (Inches)	CENTURY-LINE® SLEEVE			STEEL SLEEVE			CAST OR CORE BIT DRILLED HOLE		
		Model Number	LINK-SEAL® Size	Links Per Seal	Model Number	LINK-SEAL® Size	Links Per Seal	Hole I.D.	LINK-SEAL® Size	Links Per Seal
2	2.500	CS-4-*	LS-300-***	6	WS-3-½-22-S-*	LS-200-***	8	4.000	LS-300-***	6
2¼	2.750	CS-4-*	LS-275-***	10	WS-4-23-S-*	LS-200-***	9	4.000	LS-200-***	9
3	3.960	CS-6-*	LS-340-***	10	WS-6-28-S-*	LS-340-***	9	6.000	LS-315-***	10
4	4.800	CS-8-*	LS-410-***	7	WS-8-32-S-*	LS-410-***	7	8.000	LS-410-***	7
6	6.900	CS-10-*	LS-475-***	10	WS-10-36-S-*	LS-410-***	10	10.000	LS-410-***	10
8	9.050	CS-12-*	LS-400-***	9	WS-12-37-S-*	LS-400-***	9	12.000	LS-400-***	9
10	11.100	CS-14-*	LS-410-***	15	WS-14-37-S-*	LS-340-***	24	14.000	LS-400-***	10
12	13.200	CS-18-*	LS-575-***	15	WS-18-37-S-*	LS-475-***	18	16.000	LS-360-***	21
14	15.300	CS-20-*	LS-475-***	20	WS-20-37-S-*	LS-575-***	17	18.000	LS-360-***	24
16	17.400	CS-22-*	LS-360-***	28	WS-22-37-S-*	LS-475-***	23	20.000	LS-360-***	27
18	19.500	CS-24-*	LS-410-***	25	WS-24-37-S-*	LS-575-***	21	24.000	LS-525-***	17
20	21.600	CS-25-*	LS-400-***	20	WS-26-37-S-*	LS-475-***	27	26.000	LS-525-***	19
24	25.800	CC-30-**	LS-400-***	23	WS-30-37-S-*	LS-400-***	23	28.000	LS-425-***	23
30	32.000	CC-38-**	LS-500-***	28	WS-36-37-S-*	LS-400-***	29	36.000	LS-575-***	34
36	38.300	CC-44-**	LS-500-***	33	WS-44-½-37-S-*	LS-500-***	33	42.000	LS-575-***	40
42	44.500	CC-50-**	LS-500-***	38	WS-50-37-S-*	LS-500-***	38	50.000	LS-500-***	38
48	50.800	CC-56-**	LS-500-***	43	WS-57-37-S-*	LS-500-***	43	56.000	LS-500-***	43

= Specify sleeve length in inches ** = See CELL-CAST® Page 25 *** = Specify LS Model C, S-316, L...etc when ordering (Example LS-475-C-17)

Technically there is no limit to the conduit or pipe size that can be sealed using LINK-SEAL® Modular Seals. Please contact factory for sizes not listed and for CS model plastic sleeves for walls less than 8" thick.

Sizing Procedure - Method 1



CAST IRON SOIL PIPE (EXTRA HEAVY)

Pipe Size (Nom.)	Actual O.D. (Inches)	CENTURY-LINE® SLEEVE			STEEL SLEEVE			CAST OR CORE BIT DRILLED HOLE		
		Model Number	LINK-SEAL® Size	Links Per Seal	Model Number	LINK-SEAL® Size	Links Per Seal	Hole I.D.	LINK-SEAL® Size	Links Per Seal
2	2.380	CS-4-*	LS-300-***	6	WS-3-½-22-S-*	LS-200-***	8	4.000	LS-300-***	6
3	3.500	CS-5-*	LS-315-***	9	WS-6-28-S-*	LS-360-***	7	5.000	LS-300-***	8
4	4.500	CS-8-*	LS-475-***	8	WS-6-28-S-*	LS-300-***	10	6.000	LS-300-***	10
5	5.500	CS-8-*	LS-360-***	10	WS-8-32-S-*	LS-340-***	13	8.000	LS-340-***	13
6	6.500	CS-8-*	LS-315-***	15	WS-10-36-S-*	LS-475-***	10	10.000	LS-475-***	10
8	8.620	CS-12-*	LS-475-***	12	WS-12-37-S-*	LS-475-***	12	12.000	LS-475-***	12
10	10.750	CS-14-*	LS-410-***	15	WS-14-37-S-*	LS-425-***	10	14.000	LS-475-***	14
12	12.750	CS-16-*	LS-475-***	17	WS-16-37-S-*	LS-425-***	12	16.000	LS-475-***	17
15	15.880	CS-20-*	LS-410-***	21	WS-20-37-S-*	LS-475-***	20	18.000	LS-340-***	33

= Specify sleeve length in inches ** = See CELL-CAST® Page 25 *** = Specify LS Model C, S-316, L...etc when ordering (Example LS-475-C-17)

CAST IRON SOIL PIPE (SERVICE WEIGHT)

Pipe Size (Nom.)	Actual O.D. (Inches)	CENTURY-LINE® SLEEVE			STEEL SLEEVE			CAST OR CORE BIT DRILLED HOLE		
		Model Number	LINK-SEAL® Size	Links Per Seal	Model Number	LINK-SEAL® Size	Links Per Seal	Hole I.D.	LINK-SEAL® Size	Links Per Seal
2	2.300	CS-4-*	LS-300-***	6	WS-4-23-S-*	LS-315-***	6	4.000	LS-315-***	6
3	3.300	CS-5-*	LS-300-***	8	WS-6-28-S-*	LS-360-***	7	5.000	LS-300-***	8
4	4.300	CS-6-*	LS-300-***	10	WS-6-28-S-*	LS-315-***	10	6.000	LS-300-***	10
5	5.300	CS-8-*	LS-410-***	8	WS-8-32-S-*	LS-360-***	9	8.000	LS-360-***	9
6	6.300	CS-8-*	LS-315-***	15	WS-8-32-S-*	LS-315-***	15	8.000	LS-315-***	15
8	8.380	CS-10-*	LS-325-***	9	WS-10-36-S-*	LS-315-***	19	10.000	LS-315-***	19
10	10.500	CS-14-*	LS-475-***	14	WS-14-37-S-*	LS-360-***	17	14.000	LS-475-***	14
12	12.500	CS-18-*	LS-500-***	12	WS-16-37-S-*	LS-360-***	20	16.000	LS-475-***	17
15	15.620	CS-20-*	LS-475-***	20	WS-20-37-S-*	LS-475-***	20	18.000	LS-425-***	14

= Specify sleeve length in inches ** = See CELL-CAST® Page 25 *** = Specify LS Model C, S-316, L...etc when ordering (Example LS-475-C-17)

Sizing Procedure - Method 1



ELECTRICAL METALLIC TUBING (EMT) THIN WALL

Pipe Size (Nom.)	Actual O.D. (Inches)	CENTURY-LINE® SLEEVE			STEEL SLEEVE			CAST OR CORE BIT DRILLED HOLE		
		Model Number	LINK-SEAL® Size	Links Per Seal	Model Number	LINK-SEAL® Size	Links Per Seal	Hole I.D.	LINK-SEAL® Size	Links Per Seal
½	0.706	CS-2-*	LS-275-***	4	WS-2-15-S-*	LS-275-***	5	2.000	LS-275-***	4
¾	0.922	CS-2-*	LS-200-***	4	WS-2-½-20-S-*	LS-275-***	6	2.000	LS-200-***	4
1	1.163	CS-3-*	LS-315-***	4	WS-2-½-20-S-*	LS-275-***	6	3.000	LS-315-***	4
1¼	1.510	CS-3-*	LS-275-***	8	WS-3-30-S-*	LS-275-***	7	3.000	LS-275-***	8
1½	1.740	CS-3½-*	LS-300-***	5	WS-3-21-S-*	LS-275-***	8	3.000	LS-200-***	6
2	2.197	CS-4-*	LS-315-***	6	WS-3-½-22-S-*	LS-275-***	10	4.000	LS-315-***	6
2½	2.875	CS-4-*	LS-200-***	9	WS-4-23-S-*	LS-200-***	9	4.000	LS-200-***	9
3	3.500	CS-5-*	LS-315-***	9	WS-6-28-S-*	LS-360-***	7	5.000	LS-300-***	8
4	4.500	CS-8-*	LS-475-***	8	WS-6-28-S-*	LS-300-***	10	6.000	LS-300-***	10

= Specify sleeve length in inches ** = See CELL-CAST® Page 25 *** = Specify LS Model C, S-316, L...etc when ordering (Example LS-475-C-17)

INTERMEDIATE METAL CONDUIT (IMC)

Pipe Size (Nom.)	Actual O.D. (Inches)	CENTURY-LINE® SLEEVE			STEEL SLEEVE			CAST OR CORE BIT DRILLED HOLE		
		Model Number	LINK-SEAL® Size	Links Per Seal	Model Number	LINK-SEAL® Size	Links Per Seal	Hole I.D.	LINK-SEAL® Size	Links Per Seal
½	0.815	CS-2-*	LS-200-***	4	WS-2-15-S-*	LS-275-***	5	2.000	LS-200-***	4
¾	1.029	CS-2-*	LS-200-***	4	WS-2-½-20-S-*	LS-275-***	6	2.000	LS-200-***	4
1	1.290	CS-3½-*	LS-315-***	5	WS-2-½-20-S-*	LS-200-***	5	3.000	LS-300-***	4
1¼	1.638	CS-3-*	LS-275-***	8	WS-3-21-S-*	LS-275-***	8	3.000	LS-275-***	8
1½	1.883	CS-3½-*	LS-300-***	5	WS-3-21-S-*	LS-200-***	7	4.000	LS-315-***	6
2	2.360	CS-4-*	LS-300-***	6	WS-3-½-22-S-*	LS-200-***	8	4.000	LS-300-***	6
2½	2.857	CS-4-*	LS-200-***	9	WS-4-23-S-*	LS-200-***	9	4.000	LS-200-***	9
3	3.476	CS-5-*	LS-315-***	9	WS-6-28-S-*	LS-360-***	7	5.000	LS-300-***	8
3½	3.970	CS-6-*	LS-340-***	10	WS-6-28-S-*	LS-340-***	9	6.000	LS-315-***	10
4	4.466	CS-6-*	LS-315-***	11	WS-6-28-S-*	LS-300-***	10	6.000	LS-300-***	10

= Specify sleeve length in inches ** = See CELL-CAST® Page 25 *** = Specify LS Model C, S-316, L...etc when ordering (Example LS-475-C-17)

Sizing Procedure - Method 1



RIGID (RSC), ALUMINUM (ASC), GALVANIZED (GSC), NON-METALLIC CONDUIT (NRC)

Pipe Size (Nom.)	Actual O.D. (Inches)	CENTURY-LINE® SLEEVE			STEEL SLEEVE			CAST OR CORE BIT DRILLED HOLE		
		Model Number	LINK-SEAL® Size	Links Per Seal	Model Number	LINK-SEAL® Size	Links Per Seal	Hole I.D.	LINK-SEAL® Size	Links Per Seal
½	0.840	CS-2-*	LS-200-***	4	WS-2-15-S-*	LS-275-***	5	2.000	LS-200-***	4
¾	1.050	CS-3-*	LS-315-***	4	WS-2-½-20-S-*	LS-275-***	6	3.000	LS-315-***	4
1	1.315	CS-3-*	LS-300-***	4	WS-2-½-20-S-*	LS-200-***	5	3.000	LS-300-***	4
1¼	1.660	CS-3-*	LS-275-***	7	WS-3-21-S-*	LS-275-***	8	3.000	LS-275-***	8
1½	1.900	CS-3½-*	LS-300-***	5	WS-3-21-S-*	LS-200-***	7	4.000	LS-315-***	6
2	2.375	CS-4-*	LS-300-***	6	WS-3-½-22-S-*	LS-200-***	8	4.000	LS-300-***	6
2½	2.875	CS-4-*	LS-200-***	9	WS-4-23-S-*	LS-200-***	9	4.000	LS-200-***	9
3	3.500	CS-5-*	LS-300-***	8	WS-6-28-S-*	LS-360-***	7	5.000	LS-300-***	8
3½	4.000	CS-6-*	LS-340-***	10	WS-6-28-S-*	LS-340-***	9	6.000	LS-315-***	10
4	4.500	CS-6-*	LS-300-***	10	WS-6-28-S-*	LS-300-***	10	6.000	LS-300-***	10
5	5.563	CS-8-*	LS-360-***	10	WS-8-32-S-*	LS-340-***	13	8.000	LS-340-***	13
6	6.625	CS-10-*	LS-475-***	10	WS-10-36-S-*	LS-475-***	10	10.000	LS-475-***	10

= Specify sleeve length in inches ** = See CELL-CAST® Page 25 *** = Specify LS Model C, S-316, L...etc when ordering (Example LS-475-C-17)

COPPER TUBING

Pipe Size (Nom.)	Actual O.D. (Inches)	CENTURY-LINE® SLEEVE			STEEL SLEEVE			CAST OR CORE BIT DRILLED HOLE		
		Model Number	LINK-SEAL® Size	Links Per Seal	Model Number	LINK-SEAL® Size	Links Per Seal	Hole I.D.	LINK-SEAL® Size	Links Per Seal
½	0.625	CS-2-*	LS-275-***	4	WS-2-15-S-*	LS-275-***	5	2.000	LS-275-***	4
¾	0.875	CS-2-*	LS-200-***	4	WS-2-½-20-S-*	LS-275-***	6	2.000	LS-200-***	4
1	1.125	CS-3-*	LS-315-***	4	WS-2-½-20-S-*	LS-275-***	6	3.000	LS-315-***	4
1¼	1.375	CS-3-*	LS-275-***	8	WS-2-½-20-S-*	LS-200-***	5	3.000	LS-300-***	4
1½	1.625	CS-3-*	LS-275-***	8	WS-3-21-S-*	LS-275-***	7	3.000	LS-275-***	8
2	2.125	CS-4-*	LS-315-***	6	WS-3-½-22-S-*	LS-275-***	10	4.000	LS-315-***	6
2½	2.625	CS-4-*	LS-275-***	12	WS-4-23-S-*	LS-275-***	11	4.000	LS-275-***	11
3	3.125	CS-5-*	LS-340-***	8	WS-5-25-S-*	LS-315-***	8	5.000	LS-315-***	8
4	4.125	CS-6-*	LS-315-***	11	WS-6-28-S-*	LS-315-***	10	6.000	LS-315-***	10
6	6.125	CS-8-*	LS-315-***	15	WS-8-32-S-*	LS-315-***	15	8.000	LS-315-***	15
8	8.125	CS-12-*	LS-575-***	10	WS-10-36-S-*	LS-315-***	19	12.000	LS-575-***	10
10	10.125	CS-12-*	LS-340-***	22	WS-14-37-S-*	LS-410-***	14	14.000	LS-575-***	12
12	12.125	CS-16-*	LS-575-***	14	WS-16-37-S-*	LS-410-***	16	16.000	LS-575-***	14

= Specify sleeve length in inches ** = See CELL-CAST® Page 25 *** = Specify LS Model C, S-316, L...etc when ordering (Example LS-475-C-17)



Sizing Procedure - Method 2

METHOD 2 - LINK-SEAL® MODULAR SEAL SIZING

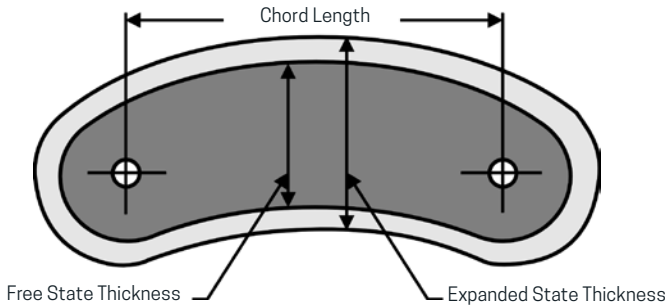

If your pipe size does not appear in the charts on pages 11-15, use the following method to select the correct LINK-SEAL® modular seal for your application.

1. Calculate the annular space. The annular space is half the difference between the actual pipe O.D. and the actual wall I.D. opening diameter. Use the following formula.

$$\text{Annular Space} = \frac{\text{Wall Opening I.D.} - \text{Actual Pipe O.D.}}{2}$$

2. From the adjacent chart, select the size closest to the annular space calculated in step 1. You have selected the correct size LINK-SEAL® modular seal if the free state thickness is less than the annular space and the expanded state thickness is greater than the annular space.
3. Calculate the number of links required to fit around the pipe and seal the annular space.

A. Determine the bolt circle for your LINK-SEAL® modular seal assembly by using the following formula.

$$\text{Bolt Circle} = \frac{\text{Wall Opening I.D.} + \text{Pipe Diameter O.D.}}{2}$$

B. Find the LINK-SEAL® modular seal chord length (Column 4) and use the following formula to determine required number of links per LINK-SEAL® modular seal assembly.

$$\text{Links per Seal} = \frac{\text{Bolt Circle} \times 3.14}{\text{Chord Length}}$$

The result must be rounded down to the next whole number. The figures are accurate if the calculation results in 13 or more links per belt. If the results are fewer than 13 links verify using the tables on pages 18-23.

Example

Wall Opening I.D. = 12"

Actual Pipe O.D. = 9.05"

Calculate the annular space (1.475"). Select the Link-Seal® modular seal size closest to the annular space. LS-400 is chosen from the chart, because 1.475" falls between 1.43 and 1.81 (the free state and expanded state thickness).

Determine the number of links for a complete assembly.

$$\text{Bolt Circle} = \frac{12 + 9.05}{2} = 10.525$$

Chord length for LS-400 = 3.625"

$$\text{Links per Seal} = \frac{10.525 \times 3.14}{3.625} = 9.12$$

Links per Seal = 9.12, rounded down = 9

Since the final calculation results are fewer than 13 links, it is advisable to verify the accuracy of the calculation by using the verification tables on pages 18-23.

LINK-SEAL® Model Selected for Penetration	Minimum Required Seating Width
LS-200/275	2.25"
LS-300/315	3.00"
LS-325/340/360	4.00"
LS-400/410/425/475	5.00"
LS-500/525/575	5.00"
LS-615/650	6.00"

Sizing Procedure - Method 2

SUGGESTED PIPE O.D. RANGE

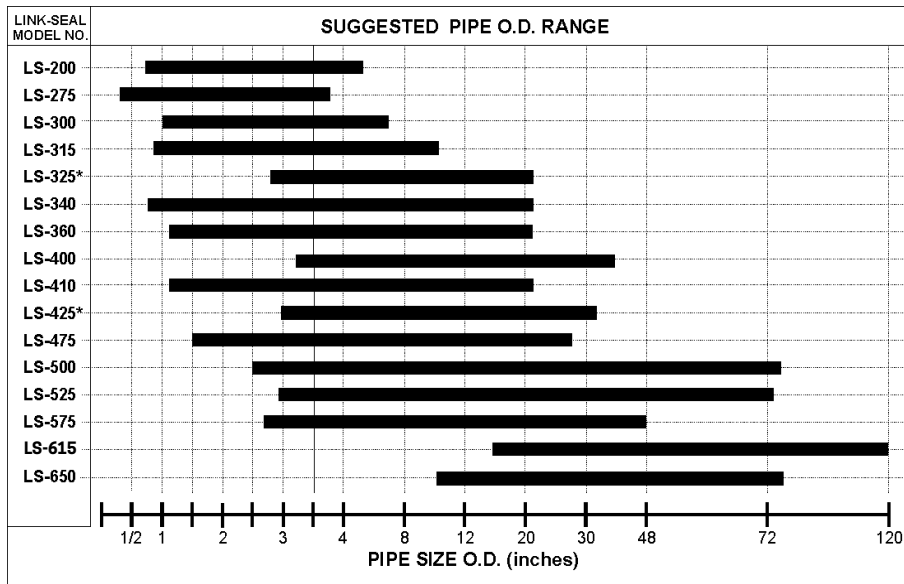

*-Whenever possible use thicker links, such as the LS-400, LS-475 or LS-500 series to provide more leeway.

Calculations using LINK-SEAL® modular seal sizing Method 2 may indicate that a smaller link may be used when compared to data on the above chart.

NOTE: This chart is based on using an average of two pipe size differential openings

LINK-SEAL® SIZE	FREE STATE THICKNESS	EXPANDED STATE THICKNESS	CHORD LENGTH
LS-200	0.50"	0.64'	1.120"
LS-275	0.62"	0.80"	0.906"
LS-300	0.71"	0.92"	1.510"
LS-315	0.82"	1.10"	1.469"
LS-325	0.94"	1.14"	3.110"
LS-340	1.05"	1.33"	1.575"
LS-360	1.29"	1.65"	2.106"
LS-400	1.43"	1.87"	3.622"
LS-410	1.48"	1.91"	2.598"
LS-425	1.13"	1.43"	3.622"
LS-475	1.62"	2.08"	2.630"
LS-500	2.37"	2.81"	3.860"
LS-525	2.18"	2.58"	3.860"
LS-575	1.88"	2.35"	3.100"
LS-615	3.20"	4.00"	6.000"
LS-650	2.76"	3.57"	4.16"

***Free state thickness** includes an insertion tolerance, and therefore, differs from the actual thickness as listed in LINK-SEAL® modular seal dimensional data on page 10.



Sizing Procedure - Method 2 (Verification)

VERIFICATION - LINK-SEAL® MODULAR SEAL SIZING

The following charts will allow you to confirm the accuracy of this information.

1. Refer to the chart for the LINK-SEAL® modular seal size calculated in Sizing Procedure - Method 2. (LS-200, LS-300 etc.)
2. Find the range your pipe O.D. falls within. (It may fall in either Range #1 or Range #2).

You now have minimum and maximum wall opening dimensions. If your wall opening size falls between these dimensions, your LINK-SEAL® modular seal size is correct. You may also verify the number of links from column 6. If your wall opening size is not in the range indicated by the chart, either choose another LINK-SEAL® modular seal size, change your wall opening size or call GPT for assistance.

Example

LINK-SEAL® Size = LS-300 **2.900 falls within Range #2 on LS-300 Chart**
 Actual Pipe O.D. = 2.900

Determine Minimum Wall Opening = $2.900 + 1.408$
 (from col. 4)

Minimum Wall Opening = $2.900 + 1.408 = 4.308$

Determine Maximum Wall Opening = $2.900 + 1.831$
 (from col. 5)

**Maximum Wall Opening = $2.900 + 1.831 = 4.731$
 Number of Links = 7 (from col. 6)**

LINK-SEAL® LS-200 VERIFICATION CHART

Range #1 Pipe O.D. Min. - Max.	Range #2 Pipe O.D. Min. - Max.	Range #1 Minimum Wall Opening	Range #2 Pipe O.D. plus Number Below = Min. Wall Opening	Range #1 & 2 Pipe O.D. plus Number Below = Max Wall Opening	No. Links/ Seal
0.757-0.909	0.909-1.084	2.033	1.124	1.277	4
1.072-1.323	1.323-1.475	2.349	1.026	1.277	5
1.400-1.713	1.713-1.862	2.677	0.964	1.277	6
1.775-2.051	2.051-2.208	3.052	1.000	1.277	7
2.146-2.390	2.390-2.563	3.422	1.032	1.277	8
2.512-2.731	2.731-2.925	3.789	1.057	1.277	9
2.874-3.074	3.074-3.291	4.151	1.077	1.277	10
3.235-3.419	3.419-3.658	4.511	1.093	1.277	11
3.593-3.764	3.764-4.027	4.870	1.106	1.277	12

LINK-SEAL® LS-275 VERIFICATION CHART

Range #1 Pipe O.D. Min. - Max.	Range #2 Pipe O.D. Min. - Max.	Range #1 Minimum Wall Opening	Range #2 Pipe O.D. plus Number Below = Min. Wall Opening	Range #1 & 2 Pipe O.D. plus Number Below = Max Wall Opening	No. Links/ Seal
0.194-0.554	0.554-0.797	1.786	1.231	1.592	4
0.475-0.828	0.828-1.190	2.067	1.239	1.592	5
0.773-1.079	1.079-1.550	2.365	1.286	1.592	6
1.062-1.334	1.334-1.917	2.654	1.320	1.592	7
1.345-1.593	1.593-2.289	2.937	1.344	1.592	8
1.625-1.853	1.853-2.663	3.216	1.363	1.592	9
1.901-2.115	2.115-3.039	3.493	1.378	1.592	10
2.176-2.378	2.378-3.417	3.768	1.391	1.592	11
2.450-2.641	2.641-3.795	4.042	1.401	1.592	12

Sizing Procedure - Method 2 (Verification)

LINK-SEAL® LS-300 VERIFICATION CHART

Range #1 Pipe O.D. Min. - Max.	Range #2 Pipe O.D. Min. - Max.	Range #1 Minimum Wall Opening	Range #2 Pipe O.D. plus Number Below = Min. Wall Opening	Range #1 & 2 Pipe O.D. plus Number Below = Max Wall Opening	No. Links/ Seal
1.018-1.278	1.278-1.415	2.849	1.571	1.831	4
1.460-1.857	1.857-2.024	3.291	1.434	1.831	5
1.919-2.404	2.404-2.605	3.750	1.346	1.831	6
2.449-2.873	2.873-3.107	4.280	1.408	1.831	7
2.969-3.347	3.347-3.617	4.800	1.453	1.831	8
3.482-3.825	3.825-4.132	5.313	1.487	1.831	9
3.990-4.306	4.306-4.650	5.821	1.515	1.831	10
4.494-4.788	4.788-5.171	6.325	1.538	1.831	11
4.996-5.271	5.271-5.693	6.828	1.556	1.831	12

LINK-SEAL® LS-315 VERIFICATION CHART

Range #1 Pipe O.D. Min. - Max.	Range #2 Pipe O.D. Min. - Max.	Range #1 Minimum Wall Opening	Range #2 Pipe O.D. plus Number Below = Min. Wall Opening	Range #1 & 2 Pipe O.D. plus Number Below = Max Wall Opening	No. Links/ Seal
0.665-0.982	0.982-1.208	2.860	1.878	2.195	4
1.082-1.530	1.530-1.795	3.278	1.748	2.195	5
1.517-2.047	2.047-2.359	3.712	1.665	2.195	6
1.961-2.549	2.549-2.917	4.156	1.607	2.195	7
2.448-3.003	3.003-3.428	4.643	1.640	2.195	8
2.933-3.455	3.455-3.941	5.128	1.673	2.195	9
3.413-3.909	3.909-4.458	5.609	1.699	2.195	10
3.891-4.366	4.366-4.977	6.086	1.720	2.195	11
4.366-4.823	4.823-5.498	6.561	1.738	2.195	12

LINK-SEAL® LS-325 VERIFICATION CHART

Range #1 Pipe O.D. Min. - Max.	Range #2 Pipe O.D. Min. - Max.	Range #1 Minimum Wall Opening	Range #2 Pipe O.D. plus Number Below = Min. Wall Opening	Range #1 & 2 Pipe O.D. plus Number Below = Max Wall Opening	No. Links/ Seal
2.593-2.593	2.593-2.775	5.214	2.272	2.272	4
3.748-3.748	3.748-4.010	6.095	2.272	2.272	5
4.739-4.839	4.839-5.178	7.012	2.172	2.272	6
5.675-5.896	5.896-6.309	7.947	2.051	2.272	7
6.621-6.933	6.933-7.418	8.893	1.961	2.272	8
7.574-7.955	7.955-8.512	9.846	1.891	2.272	9
8.532-8.968	8.968-9.596	10.805	1.836	2.272	10
9.494-9.975	9.975-10.673	11.766	1.791	2.272	11
10.458-10.976	10.976-11.744	12.730	1.754	2.272	12



Sizing Procedure - Method 2 (Verification)

LINK-SEAL® LS-340 VERIFICATION CHART

Range #1 Pipe O.D. Min. - Max.	Range #2 Pipe O.D. Min. - Max.	Range #1 Minimum Wall Opening	Range #2 Pipe O.D. plus Number Below = Min. Wall Opening	Range #1 & 2 Pipe O.D. plus Number Below = Max Wall Opening	No. Links/ Seal
0.544-0.914	0.914-1.032	3.204	2.290	2.660	4
0.992-1.501	1.501-1.695	3.652	2.151	2.660	5
1.457-2.055	2.055-2.320	4.117	2.062	2.660	6
1.932-2.592	2.592-2.927	4.592	2.000	2.660	7
2.458-3.073	3.073-3.469	5.118	2.046	2.660	8
2.978-3.557	3.557-4.016	5.638	2.081	2.660	9
3.493-4.004	4.004-4.565	6.153	2.109	2.660	10
4.004-4.532	4.532-5.117	6.664	2.132	2.660	11
4.512-5.022	5.022-5.670	7.172	2.151	2.660	12

LINK-SEAL® LS-360 VERIFICATION CHART

Range #1 Pipe O.D. Min. - Max.	Range #2 Pipe O.D. Min. - Max.	Range #1 Minimum Wall Opening	Range #2 Pipe O.D. plus Number Below = Min. Wall Opening	Range #1 & 2 Pipe O.D. plus Number Below = Max Wall Opening	No. Links/ Seal
0.901-1.269	1.269-1.430	4.200	2.931	3.299	4
1.502-2.056	2.056-2.318	4.800	2.744	3.299	5
2.127-2.801	2.801-3.156	5.426	2.625	3.299	6
2.765-3.522	3.522-3.969	6.063	2.542	3.299	7
3.410-4.228	4.228-4.765	6.709	2.480	3.299	8
4.107-4.879	4.879-5.498	7.406	2.528	3.299	9
4.798-5.532	5.532-6.235	8.097	2.565	3.299	10
5.485-6.188	6.188-6.974	8.784	2.596	3.299	11
6.168-6.845	6.845-7.715	9.467	2.621	3.299	12

LINK-SEAL® LS-400 VERIFICATION CHART

Range #1 Pipe O.D. Min. - Max.	Range #2 Pipe O.D. Min. - Max.	Range #1 Minimum Wall Opening	Range #2 Pipe O.D. plus Number Below = Min. Wall Opening	Range #1 & 2 Pipe O.D. plus Number Below = Max Wall Opening	No. Links/ Seal
2.711-2.711	2.711-3.350	6.490	3.748	3.748	4
3.779-4.071	4.071-4.920	7.527	3.456	3.748	5
4.858-5.356	5.356-6.267	8.606	3.250	3.748	6
5.960-6.601	6.601-7.671	9.708	3.107	3.748	7
7.074-7.821	7.821-8.938	10.822	3.001	3.748	8
8.196-9.025	9.025-10.163	11.944	2.919	3.748	9
9.325-10.218	10.218-11.363	13.073	2.854	3.748	10
10.457-11.403	11.403-12.549	14.205	2.802	3.748	11
11.593-12.583	12.583-13.735	15.341	2.758	3.748	12

Sizing Procedure - Method 2 (Verification)

LINK-SEAL® LS-410 VERIFICATION CHART

Range #1 Pipe O.D. Min. - Max.	Range #2 Pipe O.D. Min. - Max.	Range #1 Minimum Wall Opening	Range #2 Pipe O.D. plus Number Below = Min. Wall Opening	Range #1 & 2 Pipe O.D. plus Number Below = Max Wall Opening	No. Links/ Seal
1.288-1.677	1.677-1.888	5.110	3.433	3.822	4
2.034-2.655	2.655-2.989	5.856	3.201	3.822	5
2.809-3.579	3.579-4.029	6.632	3.053	3.822	6
3.601-4.473	4.473-5.037	7.423	2.950	3.822	7
4.402-5.350	5.350-6.025	8.224	2.874	3.822	8
5.268-6.157	6.157-6.933	9.090	2.933	3.822	9
6.125-6.968	6.968-7.846	9.948	2.979	3.822	10
6.977-7.782	7.782-8.763	10.800	3.017	3.822	11
7.825-8.599	8.599-9.682	11.647	3.049	3.822	12

LINK-SEAL® LS-425 VERIFICATION CHART

Range #1 Pipe O.D. Min. - Max.	Range #2 Pipe O.D. Min. - Max.	Range #1 Minimum Wall Opening	Range #2 Pipe O.D. plus Number Below = Min. Wall Opening	Range #1 & 2 Pipe O.D. plus Number Below = Max Wall Opening	No. Links/ Seal
3.039-3.039	3.039-3.312	6.186	2.867	2.867	4
4.360-4.403	4.403-4.799	7.227	2.824	2.867	5
5.442-5.691	5.691-6.204	8.309	2.618	2.867	6
6.546-6.940	6.940-7.564	9.413	2.474	2.867	7
7.664-8.163	8.163-8.898	10.531	2.367	2.867	8
8.790-9.371	9.371-10.214	11.656	2.286	2.867	9
9.921-10.567	10.567-11.519	12.788	2.220	2.867	10
11.057-11.756	11.756-12.814	13.924	2.168	2.867	11
12.195-12.939	12.939-14.103	15.062	2.124	2.867	12

LINK-SEAL® LS-475 VERIFICATION CHART

Range #1 Pipe O.D. Min. - Max.	Range #2 Pipe O.D. Min. - Max.	Range #1 Minimum Wall Opening	Range #2 Pipe O.D. plus Number Below = Min. Wall Opening	Range #1 & 2 Pipe O.D. plus Number Below = Max Wall Opening	No. Links/ Seal
1.017-1.490	1.490-1.773	5.174	3.685	4.158	4
1.750-2.451	2.451-2.754	5.907	3.457	4.158	5
2.512-3.359	3.359-3.692	6.670	3.311	4.158	6
3.291-4.238	4.238-4.621	7.448	3.210	4.158	7
4.078-5.101	5.101-5.544	8.236	3.135	4.158	8
4.920-5.903	5.903-6.493	9.078	3.175	4.158	9
5.763-6.700	6.700-7.272	9.921	3.221	4.158	10
6.601-7.501	7.501-8.139	10.758	3.258	4.158	11
7.434-8.303	8.303-9.009	11.592	3.289	4.158	12



Sizing Procedure - Method 2 (Verification)

LINK-SEAL® LS-500 VERIFICATION CHART

Range #1 Pipe O.D. Min. - Max.	Range #2 Pipe O.D. Min. - Max.	Range #1 Minimum Wall Opening	Range #2 Pipe O.D. plus Number Below = Min. Wall Opening	Range #1 & 2 Pipe O.D. plus Number Below = Max Wall Opening	No. Links/Seal
2.065-2.065	2.065-2.271	7.778	5.625	5.625	4
3.249-3.503	3.503-3.853	8.874	5.372	5.625	5
4.391-4.861	4.861-5.347	10.016	5.154	5.625	6
5.555-6.177	6.177-6.795	11.180	5.003	5.625	7
6.733-7.467	7.467-8.214	12.358	4.890	5.625	8
7.920-8.740	8.740-9.614	13.545	4.804	5.625	9
9.113-10.002	10.002-11.002	14.738	4.736	5.625	10
10.310-11.255	11.255-12.380	15.935	4.680	5.625	11
11.510-12.502	12.502-13.752	17.135	4.634	5.625	12

LINK-SEAL® LS-525 VERIFICATION CHART

Range #1 Pipe O.D. Min. - Max.	Range #2 Pipe O.D. Min. - Max.	Range #1 Minimum Wall Opening	Range #2 Pipe O.D. plus Number Below = Min. Wall Opening	Range #1 & 2 Pipe O.D. plus Number Below = Max Wall Opening	No. Links/Seal
2.330-2.330	2.330-2.565	7.676	5.156	5.156	4
3.634-3.791	3.791-4.337	8.791	5.000	5.156	5
4.794-5.172	5.172-6.002	9.950	4.779	5.156	6
5.977-6.509	6.509-7.555	11.133	4.625	5.156	7
7.174-7.819	7.819-9.003	12.330	4.511	5.156	8
8.379-9.113	9.113-10.364	13.536	4.423	5.156	9
9.592-10.395	10.395-11.642	14.748	4.353	5.156	10
10.808-11.668	11.668-12.817	15.965	4.297	5.156	11
12.028-12.935	12.935-13.825	17.184	4.250	5.156	12

LINK-SEAL® LS-575 VERIFICATION CHART

Range #1 Pipe O.D. Min. - Max.	Range #2 Pipe O.D. Min. - Max.	Range #1 Minimum Wall Opening	Range #2 Pipe O.D. plus Number Below = Min. Wall Opening	Range #1 & 2 Pipe O.D. plus Number Below = Max Wall Opening	No. Links/Seal
1.554-1.698	1.698-1.911	6.259	4.561	4.706	4
2.444-2.865	2.865-3.124	7.149	4.284	4.706	5
3.370-3.968	3.968-4.275	8.075	4.108	4.706	6
4.314-5.036	5.036-5.402	9.020	3.984	4.706	7
5.270-6.082	6.082-6.514	9.976	3.894	4.706	8
6.233-7.116	7.116-7.616	10.939	3.824	4.706	9
7.201-8.139	8.139-8.710	11.907	3.768	4.706	10
8.173-9.156	9.156-9.797	12.879	3.723	4.706	11
9.147-10.168	10.168-10.880	13.853	3.685	4.706	12

Sizing Procedure - Method 2 (Verification)

LINK-SEAL® LS-615 VERIFICATION CHART

Range #1 Pipe O.D. Min. - Max.	Range #2 Pipe O.D. Min. - Max.	Range #1 Minimum Wall Opening	Range #2 Pipe O.D. plus Number Below = Min. Wall Opening	Range #1 & 2 Pipe O.D. plus Number Below = Max Wall Opening	No. Links/ Seal
8.358-8.358	8.358-8.784	16.334	7.416	7.416	6
10.210-10.425	10.425-10.956	17.626	7.202	7.416	7
11.605-12.450	12.450-13.085	19.021	6.571	7.416	8
13.214-14.450	14.450-15.187	20.630	6.181	7.416	9
15.194-16.323	16.323-17.155	22.611	6.288	7.416	10
17.162-18.203	18.203-19.131	24.578	6.376	7.416	11
19.120-20.088	20.088-21.113	26.536	6.448	7.416	12

LINK-SEAL® LS-650 VERIFICATION CHART

Range #1 Pipe O.D. Min. - Max.	Range #2 Pipe O.D. Min. - Max.	Range #1 Minimum Wall Opening	Range #2 Pipe O.D. plus Number Below = Min. Wall Opening	Range #1 & 2 Pipe O.D. plus Number Below = Max Wall Opening	No. Links/ Seal
3.882 - 4.968	4.968 - 5.221	11.032	6.064	6.670	6
5.144 - 6.394	6.394 - 6.720	12.294	5.900	6.670	7
6.421 - 7.793	7.793 - 8.190	13.571	5.778	6.670	8
7.708 - 9.173	9.173 - 9.641	14.858	5.685	6.670	9
9.001 - 10.154	10.154 - 11.078	16.151	5.997	6.670	10
10.299 - 11.898	11.898 - 12.505	17.449	5.551	6.670	11
11.600 - 13.250	13.250 - 13.926	18.750	5.500	6.670	12



CENTURY-LINE® Engineered Sleeves

CENTURY-LINE® SLEEVES

CENTURY-LINE® Sleeves are used to create circular holes in concrete poured barriers of all types including; walls, floors and ceilings. Molded from non-conductive, high impact resistant HDPE, CENTURY-LINE® sleeves are lightweight and easily installed by one construction worker without use of cranes or hoists. They are available in 16 diameters ranging from 2" to 25" (51mm - 635mm) and shipped, from stock, in any desired length.

FEATURES

16 sizes - 2" to 25" in diameter (Local stock, drop ship overnight)

In the event of a field or engineering change, sleeves may be cut shorter at the job site using ordinary hand tools. Standard sleeves are 16" (406mm) in length. Longer length models may also be quickly fabricated as a custom ordered item.

1/8 the weight of steel

CENTURY-LINE® sleeves are light enough for one worker to install without a crane, hoist or helper which reduces installation time and costs. CENTURY-LINE® sleeves are easy to stock and far less expensive to ship, when compared to steel sleeves.

Resists water migration

The 2" (50.8mm) water stop collar not only anchors the sleeve in position but creates a path against the migration of water around the outside of the sleeve.

Adjusts to wall thickness

CENTURY-LINE® sleeves' unique hollow water stop collar acts like an expansion joint, adjusting (up to 1/2" - 12.7mm) to the thickness of the wall. This compressive force reacts against the forms like a spring, creating pressure and maintains proper sleeve location within the form.

Nailer end caps position sleeve precisely in form

Specially designed end caps provide an ideal method for attaching CENTURY-LINE® sleeves to the concrete forms. The end caps assure that the sleeve holds its circular configuration during the pour. In addition to keeping out wet concrete, they also prevent dirt from entering the sleeve during backfill operations or the interim construction period.

Tough high density polyethylene (HDPE) construction

High impact resistant HDPE also provides excellent resistance to acids, alkalins and other organic solvents. Ideal for cathodic protection systems, these non-conductive sleeves will neither rust, corrode or degrade. Low-temperature properties are such that they may be installed under any weather conditions suitable for pouring concrete. High temperature application limit is 150°F (66°C). The sleeve is molded with a texture on the outside surface to assure a better bond than most plastic to concrete interfaces.

Used for shotcrete wall applications

For shotcrete applications, CENTURY-LINE® sleeves are easily positioned to wall form with threaded rod, and the end caps protect the sleeve penetration while the wall is formed.

Weight Comparison	
WS Steel Sleeve WS-12-37-S-12 = 60 lbs.	Century-Line® Sleeve CS-12-12 = 6.5 lbs.

WEIGHTS AND DIMENSIONAL DATA MODEL CS (16" LENGTH)

MODEL	I.D. (In)	I.D. (mm)	O.D. (In)*	lbs.	Kg.
CS-2	1.98	50.04	2.13	0.70	0.32
CS-3	2.94	73.15	3.19	1.30	0.59
CS-3½	3.38	84.07	3.63	1.50	0.68
CS-4	4.03	101.60	4.38	2.00	0.90
CS-5	5.14	130.30	5.50	2.80	1.27
CS-6	6.14	155.70	6.50	3.60	1.63
CS-8	8.21	209.55	8.63	4.80	2.18
CS-10	10.19	260.35	10.63	6.40	2.90
CS-12	12.26	311.15	12.63	7.20	3.27
CS-14	14.14	360.43	14.69	11.20	5.08
CS-16	16.18	412.75	16.75	12.00	5.44
CS-18	17.45	444.50	18.00	15.50	7.03
CS-20	19.12	485.90	19.63	17.50	7.94
CS-22	20.32	527.05	21.25	21.00	9.53
CS-24	22.76	577.85	23.25	22.00	9.98
CS-25	24.81	628.65	25.25	23.00	10.43

* Water stop 2" larger than O.D.

NOTE: Swimming pool, floor and shotcrete applications; please specify exact lengths when ordering. Typically, a form is not installed on the top of a pool or floor, the CS sleeve water stop will not compress in these applications.

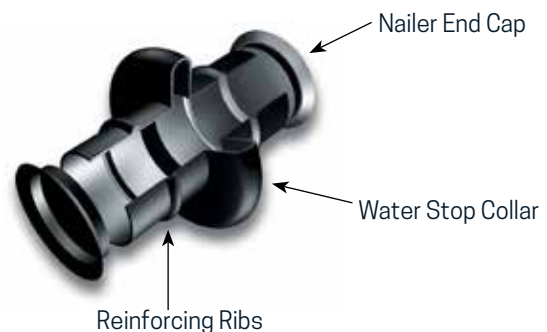

ADJUSTS TO WALL THICKNESS

CENTURY-LINE® sleeves unique hollow water stop collar works like an expansion joint, adjusting (up to 1/2") to the thickness of wall. This design creates a dynamic force against the form.



NESTING OF SLEEVES

Allow for a 2" minimum clearance between wall sleeves/ water-stop collars for concrete pour.

CELL-CAST® Interlocking Hole Forming Disks



CELL-CAST® Interlocking Hole Forming Disks are designed to produce large diameter holes in poured concrete structures. Molded from non-conductive plastic, CELL-CAST® disks are lightweight and may be installed by one construction worker. They are available in a wide range of diameters using 3" and 4" thick modular disks.

FEATURES

Economy

- » Reduces material costs by 30 to 50%
- » Cuts labor costs by 50 - 70%
- » Minimizes freight and handling charges

Quality

- » Consistently produces dimensionally accurate openings
- » Eliminates galvanic corrosion
- » Avoids potential leak path between sleeve and concrete

Installation

- » Lightweight - 1/8 the weight of steel pipe sleeves
- » Complete assembly accomplished in minutes
- » Easily installed by one construction worker

Availability

- » CELL-CAST® Disks are stocked in a variety of diameters up to 64.75" (164cm) and available for immediate delivery
- » Larger sizes are available by special order

How to Size

- » CELL-CAST® Disks are produced in 3" and 4" thicknesses and can be assembled to fit virtually any wall. For example:
- » Combine two 3" cells and one 4" cell for 10" walls
- » Combine two 4" cells and one 3" cell for 11" walls
- » Combine three 4" cells for 12" walls

Weight Comparison	
Keep the contractor in mind!	
WS Steel Sleeve WS-48-37-2-12 = 250 lbs.	Cell-Cast® Disks CC-48-4(3) = 62 lbs.

CELL-CAST® HOLE FORMING DISKS

CELL-CAST® Model No.	Hole I.D.	3" Thickness		4" Thickness	
		Lbs.	Kg.	Lbs.	Kg.
CC-30	29.25	10.0	4.53	10.4	4.71
CC-32	31.13	10.8	4.89	11.2	5.08
CC-36	34.75	12.6	5.71	13.1	5.94
CC-38	37.25	13.9	6.30	14.4	6.53
CC-42	41.38	16.3	7.39	16.8	7.62
CC-44	43.75	17.7	8.02	18.3	8.30
CC-48	47.25	20.0	9.07	20.7	9.38
CC-50	50.00	22.0	9.97	22.6	10.25
CC-54	52.63	23.9	10.84	24.6	11.15
CC-56	56.00	26.5	12.02	27.3	12.38
CC-60	59.25	29.2	13.24	30.0	13.60
CC-64	62.75	32.2	14.60	33.1	15.01
CC-66	64.75	34.0	15.42	34.9	15.83

NOTE: For walls greater than 16" and less than 8" please contact your local distributor or GPT. Please see pages 11-15 for standard pipe and CELL-CAST® Disks ordering code page 36. Threaded rod must be requested when ordering. Specify TRA at the end of the ordering code.



TYPICAL WALL OPENING SPECIFICATION

CENTURY-LINE® Sleeves - for openings to 24.81" diameter

Where pipes must pass through walls and floors of new structures, unless otherwise shown or specified, install molded non-metallic high density polyethylene Model CS CENTURY-LINE® sleeves as manufactured by GPT. Model CS sleeves have integrally formed hollow water stop sized having a minimum of four inches larger than the outside diameter of the sleeve itself and allowing 1/2" movement between wall forms to resist pour forces. Each sleeve assembly has end caps manufactured of the same material as the sleeve itself and installed at each end of the sleeve so as to prevent deformation during the initial concrete pour, and to facilitate attaching the sleeve to the wall forms. End caps will remain in place to protect the opening from residual debris and rodent entry prior to pipe insertion.

CELL-CAST® Disks - for openings from 29.25" to 64.74" diameter

The contractor will install CELL-CAST® disks, providing a round hole in conformance with LINK-SEAL® modular seal sizing data. CELL-CAST® disks consist of 3" and/or 4" lightweight interlocking polyethylene cells stacked to form the thickness of the poured concrete wall. Molded into each cell is a cavity to accept a 2" x 4" nailer.



WS Steel Wall Sleeves

WS Wall Sleeves are constructed from steel and available in a wide range of diameters and lengths. They are an excellent choice for installations where the LINK-SEAL® Modular Seal and WS sleeve assembly would be subject to extremely high temperatures or where fire seals are specified.

Continuous Weld-
Bead on both
sides

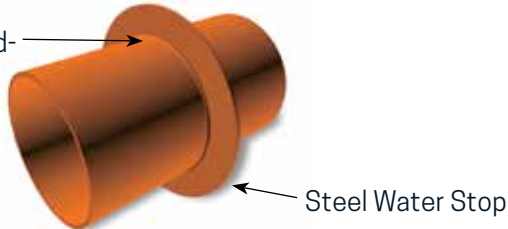

WS STEEL WALL SLEEVE SPECIFICATION

Provide WS Steel sleeves for all pipes passing through concrete or masonry structures. The WS Sleeves shall be provided free of welding slag. WS Steel Sleeve sizes through 10" shall be Schedule 40 Steel Pipe or standard wall thickness. WS Steel Sleeve sizes 12" and larger shall have a .375" or standard wall thickness. WS Sleeves through wall shall be cast in place and the pipe shall be installed centered in sleeve. The 2" collar, (water-stop) shall be the same type of steel as the WS sleeve. The collar shall be welded all around on both sides to the sleeve at the point on the sleeve that positions it at the mid-point of the structural wall when the sleeve is in place. The WS Steel Sleeve w/water-stop shall be primed inside and outside with Sherwin Williams Water Base Red Primer or approved equivalent.

MODEL WS (12" LENGTH)

Model	I.D.	Lbs.	Kg.
WS-2-15-S-12	2.07	5.53	2.51
WS-2½-20-S-12	2.47	7.91	3.58
WS-3-21-S-12	3.07	9.93	4.51
WS-3½-22-S-12	3.55	11.70	5.31
WS-4-23-S-12	4.03	13.61	6.17
WS-5-25-S-12	5.05	17.91	8.12
WS-6-28-S-12	6.07	22.73	10.31
ws-6-18-S-12	6.25	14.82	6.72
WS-8-32-S-12	7.98	33.55	15.22
ws-8-18-S-12	8.25	21.94	9.95
WS-10-36-S-12	10.02	46.12	20.92
ws-10-25-S-12	10.25	33.67	15.27
WS-12-37-S-12	12.00	60.14	27.28
WS-14-37-S-12	13.25	62.04	28.14
WS-16-37-S-12	15.25	71.04	32.22
WS-18-37-S-12	17.25	79.98	36.28
WS-20-37-S-12	19.25	90.00	40.82
WS-22-37-S-12	21.25	98.00	44.45
WS-24-37-S-12	23.25	107.00	48.53

NOTE: ws rolled sleeves (6" & 8") = .1875" wall thickness; (10") = .25" wall thickness. Intermediate sleeves available, model information on-line in a pdf file. See page 3yes, that 6 for Wall Sleeve ordering guide



Model WS Painted and WSG Galvanized Steel Wall Sleeves are an excellent choice for installations where the LINK-SEAL® Modular Seal and WS sleeve assembly would be subject to extremely high temperatures or where fire seals are specified.



WS Intermediate Sleeves are used in conjunction with LINK-SEAL® Modular Seals to seal all pipes passing through concrete or masonry structures that require two belts of seals to fill the annular space between pipe and wall. Please see page 30, sealing an oversize annulus.



Model WS Split Sleeves are used for installations where an existing pipe run needs to penetrate a wall yet to be constructed. During wall installation a split sleeve is welded around the existing pipe and positioned in the form to center the pipe. After installation a LINK-SEAL® Modular Seal is used to seal the annular space between split sleeve and pipe.

Steel Pipe Reference Schedules

WALL THICKNESS CHART FOR: BLACK STEEL, API, IPS, RSC

The following wall thickness chart has been provided to help size LINK-SEAL® modular seals in steel pipe sleeves of various wall thicknesses. To determine the Inside Diameter (I.D.) of the proposed steel wall sleeve subtract **2 times** the selected Wall Thickness (W.T.) from the actual Outside Diameter (O.D.) of the pipe.

EXAMPLE

Find the I.D. for a 5" (INCH) Schedule 40 Pipe.

Use Chart Below:

O.D. of a 5" Schedule 40 Pipe = **5.563" (INCHES)**

Wall Thickness of 5" Schedule 40 Pipe = **.258"**

Wall Thickness multiplied by 2 (.258 x 2) = **.516"**

I.D. of 5" Schedule 40 Pipe (5.563 - .516) = **5.047"**

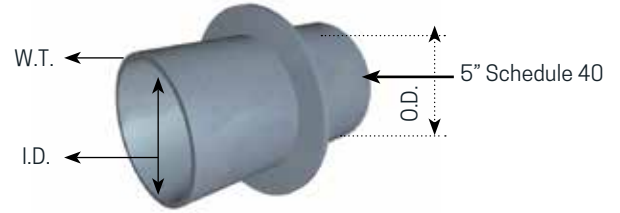

NON BOLD = WALL THICKNESS (INCHES) | STD = STANDARD | E.H. = EXTRA HEAVY

Pipe Size	O.D. Inches	SCHEDULE					STD	SCHEDULE			100	120	140	160	DBLE E.H.
		5	10	20	30	40		60	80	E.H.					
1/8"	.405	.035	.049	--	--	.068	.068	--	.095	.095	--	--	--	--	--
1/4"	.540	.049	.065	--	--	.088	.088	--	.119	.119	--	--	--	--	--
3/8"	.675	.049	.065	--	--	.091	.091	--	.126	.126	--	--	--	--	--
1/2"	.840	.065	.083	--	--	.109	.109	--	.147	.147	--	--	--	.188	.294
3/4"	1.050	.065	.083	--	--	.113	.113	--	.154	.154	--	--	--	.219	.308
1"	1.315	.065	.109	--	--	.133	.133	--	.179	.179	--	--	--	.250	.358
1 1/4"	1.660	.065	.109	--	--	.140	.140	--	.191	.191	--	--	--	.250	.382
1 1/2"	1.900	.065	.109	--	--	.145	.145	--	.200	.200	--	--	--	.281	.400
2"	2.375	.065	.109	--	--	.154	.154	--	.218	.218	--	--	--	.344	.436
2 1/2"	2.875	.083	.120	--	--	.203	.203	--	.276	.276	--	--	--	.375	.552
3"	3.500	.083	.120	--	--	.216	.216	--	.300	.300	--	--	--	.438	.600
3 1/2"	4.000	.083	.120	--	--	.226	.226	--	.318	.318	--	--	--	--	.636
4"	4.500	.083	.120	--	--	.237	.237	.281	.337	.337	--	.438	--	.531	.674
4 1/2"	5.000	--	--	--	--	.247	.247	--	.355	.355	--	--	--	--	.710
5"	5.563	.109	.134	--	--	.258	.258	--	.375	.375	--	.500	--	.625	.750
6"	6.625	.109	.134	--	--	.280	.280	--	.432	.432	--	.562	--	.719	.864
7"	7.625	--	--	--	--	--	.301	--	--	.500	--	--	--	--	.875
8"	8.625	.109	.148	.250	.277	.322	.322	.406	.500	.500	.594	.719	.812	.906	.875
9"	9.625	--	--	--	--	--	.342	--	--	.500	--	--	--	--	--
10"	10.750	.134	.165	.250	.307	.365	.365	.500	.594	.500	.719	.844	1.000	1.125	1.000
11"	11.750	--	--	--	--	--	.375	--	--	.500	--	--	--	--	--
12"	12.750	.165	.180	.250	.330	.406	.375	.562	.688	.500	.844	1.000	1.125	1.312	1.000
14"	14.000	--	.250	.312	.375	.438	.375	.594	.750	.500	.938	1.094	1.250	1.406	--
16"	16.000	--	.250	.312	.375	.500	.375	.656	.844	.500	1.031	1.219	1.438	1.594	--
18"	18.000	--	.250	.312	.438	.562	.375	.750	.938	.500	1.156	1.375	1.562	1.781	--
20"	20.000	--	.250	.375	.500	.594	.375	.812	1.031	.500	1.281	1.500	1.750	1.969	--
22"	22.000	--	.250	.375	.500	--	.375	.875	1.125	.500	1.375	1.625	1.875	2.125	--
24"	24.000	--	.250	.375	.562	.688	.375	.969	1.219	.500	1.531	1.812	2.062	2.344	--
26"	26.000	--	.312	.500	--	--	.375	--	--	.500	--	--	--	--	--
28"	28.000	--	.312	.500	.625	--	.375	--	--	.500	--	--	--	--	--
30"	30.000	--	.312	.500	.625	--	.375	--	--	.500	--	--	--	--	--
32"	32.000	--	.312	.500	.625	.688	.375	--	--	.500	--	--	--	--	--
34"	34.000	--	.312	.500	.625	.688	.375	--	--	.500	--	--	--	--	--
36"	36.000	--	.312	.500	.625	.750	.375	--	--	.500	--	--	--	--	--
38"	38.000	--	--	--	--	--	.375	--	--	.500	--	--	--	--	--
40"	40.000	--	--	--	--	--	.375	--	--	.500	--	--	--	--	--
42"	42.000	--	--	--	--	--	.375	--	--	.500	--	--	--	--	--
48"	48.000	--	--	--	--	--	.375	--	--	.500	--	--	--	--	--
54"	54.000	--	--	--	--	--	.375	--	--	.500	--	--	--	--	--
60"	60.000	--	--	--	--	--	.375	--	--	.500	--	--	--	--	--

DISCLAIMER NOTE: The above steel pipe O.D.'s are generic, GPT is not a pipe manufacturer. Please always refer to the pipe manufacturer's published/actual values.

WALL THICKNESS NOTE: It's suggested sleeves be fabricated from standard (STD) or thicker wall thickness.



LINK-SEAL® Modular Fire Seals

1-HOUR FACTORY MUTUAL APPROVED

LINK-SEAL® modular fire seals provide up to one-hour protection against flames, smoke, gases and water, even when exposed to temperatures up to 1,900°F (1,038°C).

These seals are a proprietary LINK-SEAL® modular seal design formulated from hi-temp silicone and incorporate special designed carbon steel pressure plates. For installations from 1/2" to 120" diameter LINK-SEAL® modular fire seals are used with WS wall sleeves or core bit drilled openings.

Model T - One Hour FM Approved

Approved by Factory Mutual as a 1-hour fire stop in accordance with ASTM E814-81 Fire & Hose Stream Criteria Listing #J.I.OH4A5.AC.

Model FS or FD

These are essentially two T Models back-to-back for added protection. Model FD is a dual belt of Model T for use with specification or wall thickness calls for two belts and both sides of the hole are accessible. Model FS is designed with a tie rod (nut coupler) which tightens both seals simultaneously for use when only one side of a hole is accessible.

MINIMUM WALL & FLOOR THICKNESS FOR MODEL T FIRE RATED SEALS

Link-Seal® Model	Minimum Wall or Floor Thickness
LS-200-T	2.25" (57 mm)
LS-275-T	2.25" (57 mm)
LS-300-T	3.00" (76 mm)
LS-315-T	3.00" (76 mm)
LS-325-T	4.00" (102 mm)
LS-340-T	4.00" (102 mm)
LS-360-T	4.00" (102 mm)
LS-400-T	5.00" (127 mm)
LS-410-T	5.00" (127 mm)
LS-425-T	5.00" (127 mm)
LS-475-T	5.00" (127 mm)
LS-500-T	5.00" (127 mm)
LS-525-T	5.00" (127 mm)
LS-575-T	5.00" (127 mm)

MINIMUM WALL & FLOOR THICKNESS FOR MODEL FD OR FS FIRE RATED SEALS

Link-Seal® Model	Minimum Wall or Floor Thickness
LS-200-FD or FS	4.50" (114 mm)
LS-275-FD or FS	4.50" (114 mm)
LS-300-FD or FS	6.00" (152 mm)
LS-315-FD or FS	6.00" (152 mm)
LS-325-FD or FS	8.00" (203 mm)
LS-340-FD or FS	8.00" (203 mm)
LS-360-FD or FS	8.00" (203 mm)
LS-400-FD or FS	10.00" (254 mm)
LS-410-FD or FS	10.00" (254 mm)
LS-425-FD or FS	10.00" (254 mm)
LS-475-FD or FS	10.00" (254 mm)
LS-500-FD or FS	12.00" (305 mm)
LS-525-FD or FS	12.00" (305 mm)
LS-575-FD or FS	12.00" (305 mm)

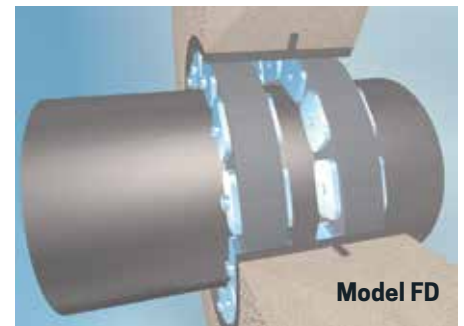
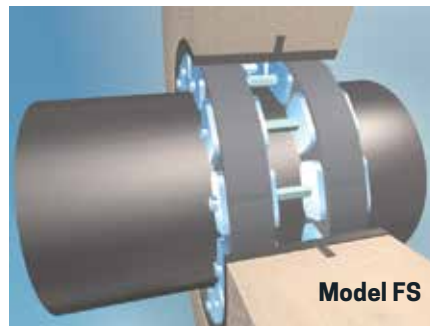
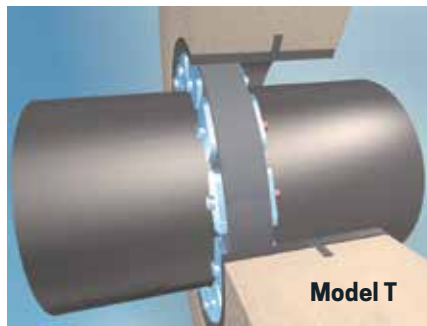

LINK-SEAL® MODULAR FIRESEALS TESTING PROCEDURES



Certified test furnace with pipe and cable penetrations and fire rated LINK-SEAL® modular seal installed in concrete floor slab. Twenty-seven thermo couples were used per slab.



Test slab being raised from furnace at completion of test. (Slab was then positioned vertically for hose stream test).



Test slab after hose stream. Cold water striking the 1,900°F slab caused scalling of concrete, but left LINK-SEAL® modular seal intact. Unexposed side showed no evidence of water damage.

Seal Pipeline Casings

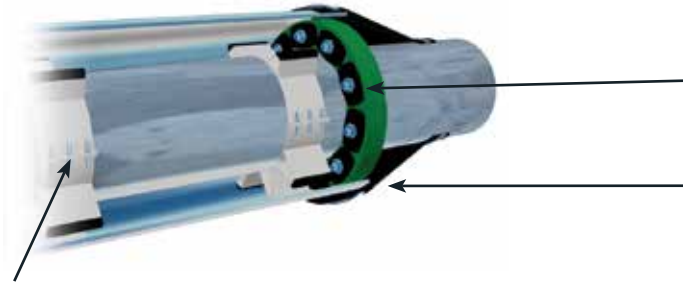

GPT CASING SPACERS METALLIC

Model C (coated) is available with 8" (208mm) or 12" (305mm) wide steel bands for 4" (10cm) to 120" (305cm) carrier pipe diameters.

Model S (stainless steel) is available with 8" (208mm) or 12" (305mm) wide steel bands for 4" (10cm) to 120" (305cm) carrier pipe diameters.

PLASTIC

Model PE (polyethylene) is available for 3/4" (19mm) through 48" (1210mm) and larger carrier pipe. (Not recommended for pipe sizes over 12".)

Ranger II all non-metallic spacers are available for 0.83" (21mm) through 37.60" (955mm) carrier pipe diameters.

LINK-SEAL® MODULAR SEALS WITH CENTERING BLOCKS

GPT END SEALS

Model "C" Custom Pull-on

Individually designed to accommodate all types of water and sewer pipes and carrier/casing combinations, made of 1/8" thick, specially compounded synthetic rubber for long life and easy installation.

Model "W" Wrap Around End Seals

Specially designed for ease of installation. Simply remove plastic backing from self-curing rubber and press exposed surfaces together. Available for all carrier/casing differentials.

Model "S" Standard Pull-on End Seals

Made of special synthetic rubber for long life and easy installation, the highly flexible "S" shaped seal is available for ANSI steel pipe specifications. Band locating ribs are on the outside, with special sealing ribs on the inside under the band to prevent leakage.

All GPT End Seals include stainless steel closure clamps.

LINK-SEAL® MODULAR SEALS WITH REINFORCED CENTERING BLOCKS

A LINK-SEAL® modular seal assembly installed at each end of pipeline casings provides positive, hydrostatic protection against the entry of water, soil or other backfill materials and reduces corrosion and ice damage. If casing isolators are not used, starting with 14" diameter assemblies, we suggest LINK-SEAL® modular seals with "centering blocks" in 25% of the links.

These centering blocks fit into molded openings in the LINK-SEAL® modular seals and are positioned in the lower 90° of each assembly. GPT centered casing isolators should also be placed within two feet of casing ends. LINK-SEAL® modular seals with centering blocks are available in LS-400, LS-500, LS-575 & LS-615 sizes.

400 SERIES - FOR CASINGS TWO PIPE SIZES LARGER THAN CARRIER PIPE

IPS CARRIER X IPS CASING Nominal	COMPLETE CASING SEAL ASSEMBLY CONSISTS OF:			BASIC LINK- SEAL® SIZE USED	COMPLETE ASSEMBLY ORDER NO.
	PLAIN LINKS	LINKS WITH CENTERING BLOCKS	TOTAL LINKS		
14" X 18"	9	4	13	LS-400	1418
16" X 20"	11	4	15	LS-400	1620
18" X 22"	13	4	17	LS-400	1822
20" X 24"	13	5	18	LS-400	2024
22" X 26"	16	5	20	LS-400	2226
24" X 28"	17	5	22	LS-400	2428
26" X 30"	17	6	23	LS-400	2630
28" X 32"	18	7	25	LS-400	2832
30" X 34"	20	7	27	LS-400	3034
32" X 36"	21	8	29	LS-400	3236
34" X 38"	22	8	30	LS-400	3438
36" X 40"	24	8	32	LS-400	3640

500 SERIES - FOR CASINGS THREE PIPE SIZES LARGER THAN CARRIER PIPE

CARRIER X CASING PIPE IPS Nominal	COMPLETE CASING SEAL ASSEMBLY CONSISTS OF:			BASIC LINK- SEAL® SIZE USED	COMPLETE ASSEMBLY ORDER NO.
	PLAIN LINKS	LINKS WITH CENTERING BLOCKS	TOTAL LINKS		
10" X 16"	7	3	10	LS-525	1016
12" X 18"	9	3	12	LS-525	1218
14" X 20"	9	4	13	LS-500	1420
16" X 22"	11	4	15	LS-500	1622
18" X 24"	12	4	16	LS-500	1824
20" X 26"	13	5	18	LS-500	2026
22" X 28"	14	6	20	LS-500	2228
24" X 30"	15	6	21	LS-500	2430
26" X 32"	17	6	23	LS-500	2632
28" X 34"	18	6	24	LS-500	2834
30" X 36"	19	7	26	LS-500	3036
32" X 38"	21	7	28	LS-500	3238
34" X 40"	21	8	29	LS-500	3440
36" X 42"	23	8	31	LS-500	3642
42" X 48"	27	9	36	LS-500	4248
48" X 54"	30	11	41	LS-500	4854
54" X 60"	34	12	46	LS-500	5460



Sealing An Oversized Annulus

THE DOUBLE ROW METHOD

Sometimes the wall opening represents a differential up to five pipe sizes larger than the carrier pipe itself. This creates an annular space that is larger than the expanded thickness of a single LINK-SEAL® modular seal assembly. A typical example is a flanged spool piece or an existing opening where piping has been removed to make way for a new installation. As a result it is necessary to use an intermediate sleeve and another belt of LINK-SEAL® modular seals.

Key design considerations when sizing an intermediate wall sleeve are:

- An intermediate sleeve must be used for a proper seal.
- The intermediate sleeve should be sized correctly to accommodate both belts of LINK-SEAL® modular seals.
- Be sure to support the actual carrier pipe properly. Neither belt of links should be responsible for supporting the carrier pipe.
- Let economics guide your selection when sizing LINK-SEAL® modular seals. However do not under size, refer to adjacent example or call GPT for sizing assistance 1-800-423-2410.

Typical Application

Wall Opening = 40" Cored Hole

Carrier Pipe = 30" API Type
(30.00" O.D.)

This is a differential of five pipe sizes: (32, 34, 36, 38, 40)

Intermediate Sleeve

WS Intermediate Steel Wall Sleeve Installation

Follow the standard published LINK-SEAL® modular seal installation techniques.

When installing an intermediate sleeve, use the following supplementary steps.

- Slide intermediate sleeve over centered pipe.
- Slide inner belt assembly into annular space.
- Slide outer belt assembly into annular space.
- Tighten outer belt first, then proceed to tightening the inner belt.

Solution:

Use an inner belt of LS-400 and an outer belt of LS-500. Intermediate sleeve should be two pipe sizes larger than the 30" carrier pipe. A 34" pipe with a 3/8" wall would be an excellent choice. Checking the LINK-SEAL® modular seal sizing chart on page 11 indicates a 30 x 34 WS sleeve requires 27 links of LS-400. The outer sleeve of 34 x 40 will require 29 links of LS-500.

For sizing assistance call our toll free number: 1-800-423-2410.

Intermediate sleeves available, information pdf file on-line. **Reduce Intermediate Sleeve Applications:** Try eliminating your intermediate sleeve needs by sizing the model **LS-650**.

Pressure Testing

To determine the amount of pressure that has built up behind a LINK-SEAL® modular seal, install our "V" modification. It is a standard LINK-SEAL® modular seal assembly in which one link has a hole molded to accept a test probe.

The probe has a NPT female connection and is inserted prior to tightening the assembly. The probe is firmly sealed by expansion of the rubber link. A pressure gauge can then be attached to monitor for leaks or pressure build-up.

How To Order

Please specify "V" with LINK-SEAL® modular seal Model Number Example: LS-400-C-V. "V" modification.

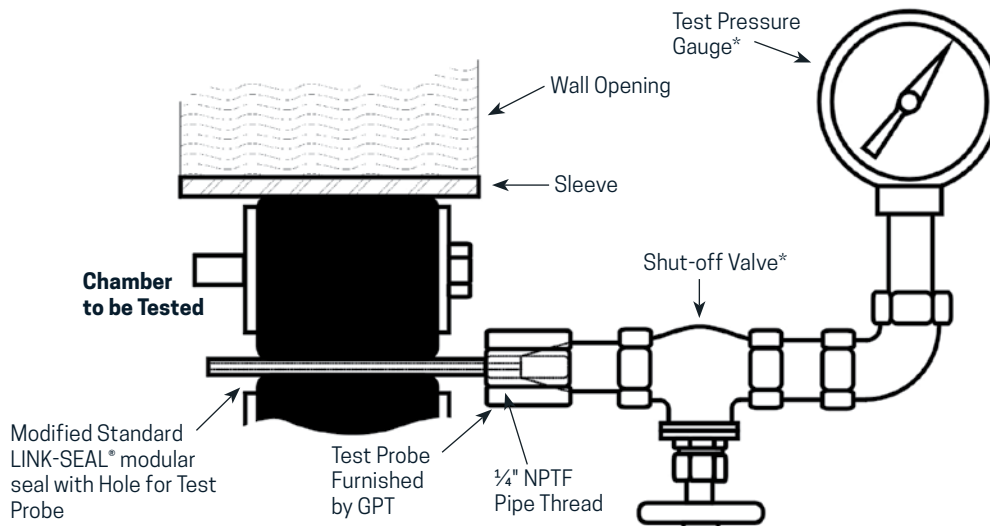

* = Not Provided by GPT

Sealing Manhole Penetrations

When LINK-SEAL® modular seals are specified for a penetration through a curved wall, the thickness must be checked to assure an adequate sealing surface. A minimum (effective) wall thickness (T_e) is required. This can be found by a scale drawing, using the adjacent formula, contacting your local stocking distributor or GPT directly.

LINK-SEAL® Model Selected for Penetrations	(T_e) Minimum
LS-200/275	2.25"
LS-300/315	3.00"
LS-325/340/360	4.00"
LS-400/410/425/475	5.00"
LS-500/525/575	5.00"
LS-615/650	6.00"

(T_e) = Required bearing surface based on the footprint of respective LINK-SEAL® modular seal model.

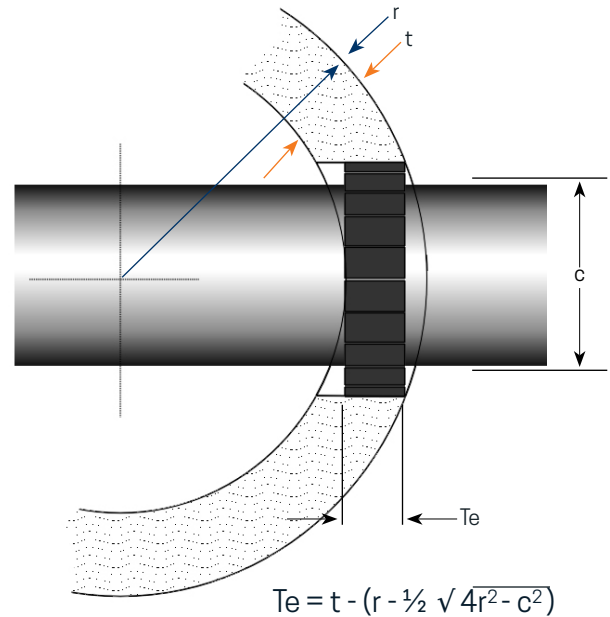

Example: 3" DI Pipe = LS-315-C-10
 t = wall thickness 5"
 r = wall outside radius 29"
 c = penetration opening I.D. 6"

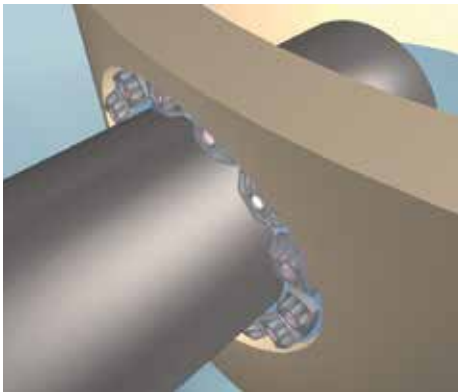

Installation Techniques - LINK-SEAL® Modular Seals

1. Center the pipe, cable or conduit in wall opening or casing. Make sure the pipe will be adequately supported on both ends. LINK-SEAL® modular seals are **not** intended to support the weight of the pipe.



5. LS-200 through LS-315 Using a hand socket allen head or off-set wrench **ONLY**, start at 12 o'clock. Do not tighten any bolt more than 4 turns at a time. Continue in a clockwise manner until links have been uniformly compressed. (Approx. 2 or 3 rotations)



2. Loosen rear pressure plate with nut just enough so links move freely. Connect both ends of belt around the pipe.

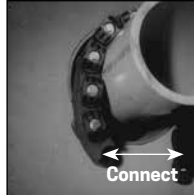

5a. LS-325 through LS-650 Using a hand socket or off-set wrench **ONLY**, start at 12 o'clock. Do not tighten any bolt more than 4 turns at a time. Continue in a clockwise manner until links have been uniformly compressed (Approx. 2 or 3 rotations).



3. Check to be sure all bolt heads are facing the installer. Extra slack or sag is normal. Do **not** remove links if extra slack exists.



6. Make 2 or 3 more passes at 4 turns per bolt **MAXIMUM**, tightening all bolts clockwise until all sealing elements **"bulge"** around all pressure plates. On type 316 stainless steel bolts, hand tighten **ONLY** without power tool.

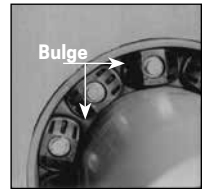

NOTE: On smaller diameter pipe, links may need to be stretched.

4. Slide belt assembly into annular space. For larger size belts, start inserting LINK-SEAL® modular seal assembly at the 6 o'clock position and work both sides up toward the 12 o'clock position in the annular space.



7. If the seal doesn't appear to be correct using the instructions provided, call GPT at 1-800-423-2410.



Installation Complete

Installation Notes: The LINK-SEAL® modular seal bolt heads are usually recessed below the wall opening or the edge of casing pipe and therefore a socket or offset wrench must be used.

Installation Techniques - LINK-SEAL® Modular Seals

ALWAYS WEAR PPE WHEN USING LINK-SEAL® MODULAR SEALS

LINK-SEAL® Modular Seal - Do's

1. Make sure pipe is centered.
2. Install the belt with the pressure plates evenly spaced.
3. Install the exact number of links indicated in sizing charts.
4. Check to make sure pipe is supported properly during backfill operations. **NOTE:** LINK-SEAL® modular seals are not intended to support the weight of the pipe.
5. Make sure seal assembly and pipe surfaces are free from dirt.
6. For tight fits, use non-polluting liquid detergent to assist installation.

LINK-SEAL® Modular Seal - Don'ts

1. Don't Install the belt with the pressure plates aimed in irregular directions. (Staggered)
2. Don't Install LINK-SEAL® modular seals where weld-beads or other irregular surfaces exist without consideration of the sealing requirements.
3. Don't torque each bolt completely before moving on to the next.
4. Don't use high speed power tools (450 rpm or more)
5. Do not use power tools on LINK-SEAL® modular seal 316 stainless steel bolts.
6. Don't use grease installing LINK-SEAL® modular seals.

CORRECT

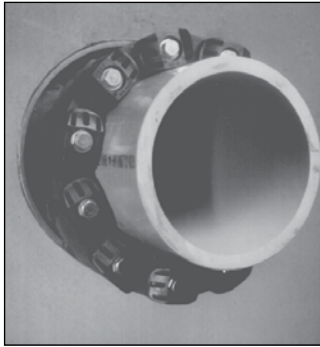

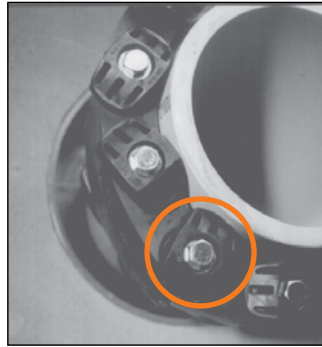

INCORRECT



If the seal doesn't appear to be correct using the techniques provided, Call GPT at 1-800-423-2410.

Hand Tools: Review provided chart below. (Tools not provided.) Tools can be purchased from hardware store, auto parts store, or home improvement store.

LINK-SEAL® Model	Tool Size/ Type Req.	Bolt Head Type
LS-200, LS-275	4mm, Allen	
LS-300, LS-315	6mm, Allen	
LS-325, LS-340, LS-360	13mm, Hex	
LS-400, LS-410, LS-425, LS-475	17mm, Hex	
LS-500, LS-525, LS-575	19mm, Hex	
LS-615	30mm, Hex	
LS-650	19mm, Hex	

Installation Techniques - CENTURY-LINE® Sleeves

CENTURY-LINE® Sleeves are thermoplastic wall or floor pipe penetration sleeves. One person working alone can usually install a CENTURY-LINE® Sleeve regardless of the size.

1. Measure the center line to position CENTURY-LINE® Sleeve end cap.



2. Nail one of the end caps at the marked centerline. A 2" minimum clearance is suggested when nesting sleeves.



3. Place the CENTURY-LINE® Sleeve on the end cap. When field cutting non standard CS sleeve lengths, the sleeve and end caps total length should be 1/4" longer than the thickness of the wall. Cut with a hand or power saw.



NOTE: To insure minimum water migration, center the water stop in wall by cutting equal lengths from each end of the sleeve, except as noted below.

ALTERNATIVE TECHNIQUES USING THREADED ROD

After nailing end cap to form, drive (threaded rod*) through the end plate and form and (thread nut*) on other side.



NOTE: Remember to measure the (threaded rod*) to match the length of the sleeve.

Place the sleeve over the end cap nailed to the form.



* = Not Provided by GPT®

Place second cap on the sleeve and use a (block of wood*) and (wing nut*) to tighten unit in place. Make certain sleeve is plumb.



ALWAYS WEAR APPROPRIATE PPE

4. Place second end cap on sleeve. Check to determine that the cap is properly inserted.



5. For additional stability, it's necessary to secure the sleeve with wire to the rebar. Insert the other end cap firmly, check that second end cap is positioned correctly, confirm sleeve length and close the form.



6. After the concrete is poured and cured, remove end caps with screw driver or crow bar. End caps may be replaced to protect sleeve until pipe penetration is made.



Wall Thickness	Cut From Left End	Dimension A	Cut From Right End	Dimension B
16"	0.0"	7.125"	0.0"	7.125"
14"	.875"	6.125"	.875"	6.125"
12"	1.875"	5.125"	1.875"	5.125"
10"	2.375"	4.625"	3.375"	3.625"
8"	2.375"	4.625"	5.375"	1.625"

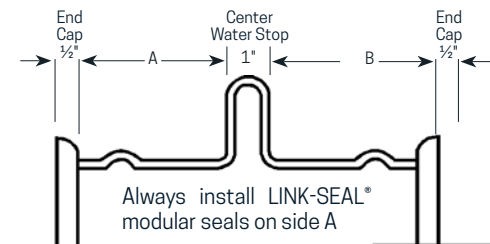

NOTES:

1. Example: To convert 16" to 12", cut 1.875" off each end.
2. Endcaps leave 1/2" depression in face of concrete.
3. On sleeves under 12" length, install LINK-SEAL® modular seal on the "long side" of the waterstop. (a) For LINK-SEAL® modular seals models LS-200, LS-275, LS-300, LS-315, LS-340 and LS-360 - install with pressure plates flush with outer edge of the sleeve. (b) For LINK-SEAL® modular seals models LS-325, LS-400, LS-410, LS-425 and LS-475 - install with pressure plates partially inserted into the sleeve. When tightened, the pressure plates will "pull" into the sleeve. (c) For LINK-SEAL® modular seals models LS-500, LS-525, LS-575, LS-615 and LS-650 - the minimum sleeve length is 10". Follow the instructions in 3 above.

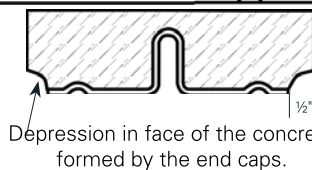

Installation Techniques - CELL-CAST® Disks

1. Locate center line where the hole is desired. This location will be used as a guide for the threaded centering assist rod.



2. A 2x4 wood nailer is included. Fasten it along with the threaded rod directly to the concrete form. This provides support and helps center the complete CELL-CAST® disk assembly.



3. Slide the first CELL-CAST® disk over the *threaded rod.

NOTE: Use only 1 threaded rod for equal distribution. More than one rod could take disks out of shape.



4. Secure the edges of the cell to the form using the provided steel spikes.



5. Additional disks are interlocked to accommodate finished wall thickness. Verify thickness is the same as wall.



6. Guide the 1" wood block over the threaded rod and secure the assembly with the wing nut provided.



7. Wrap each seam with one wrap of 2" wide tape to bridge any possible gaps.

NOTE: Tape not included. Finish insatlling concrete forms and pour concete.



8. After wall cures, wall forms are removed. The CELL-CAST® disk assembly is now ready for removal.

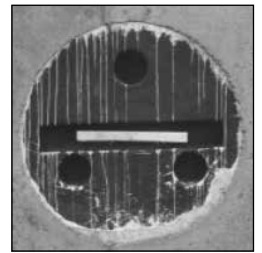

9. Chip excess concrete from the edge of the CELL-CAST® disk assembly and wall.



10. Remove disks by breaking out the entire assembly.



11. Inspect the installation. A smooth opening is important for a proper LINK-SEAL® modular seal installation. Repair voids and grind smooth any ridges.



If you should have questions using the techniques provided, Call GPT® at 1-713-747-6948 or 1-800-423-2410.

NOTE: For walls greater than 16", please contact GPT.

*Threaded rod must be requested when ordered. Make sure TRA is added to the end of the ordering code.

Product Ordering Code

LINK-SEAL® MODULAR SEALS WITH CENTURY-LINE® SLEEVES

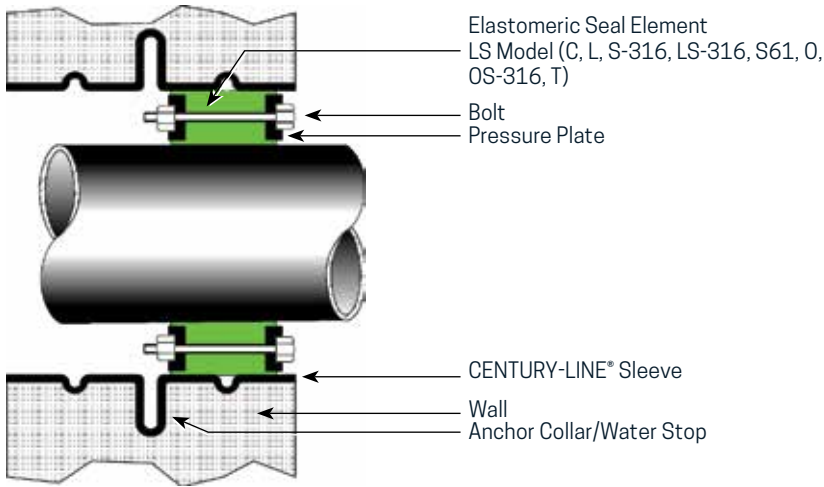

LINK-SEAL® Model No. Example

LS - 400 - C - 10

LINK-SEAL® _____
 Size _____
 Model _____
 No. of Links _____

CENTURY-LINE® Model No. Example

CS - 10 - 16 - 1

CENTURY-LINE® _____
 Sleeve Length (In.) _____
 No. of Units _____

LINK-SEAL® MODULAR SEALS WITH MODEL WS WALL SLEEVES

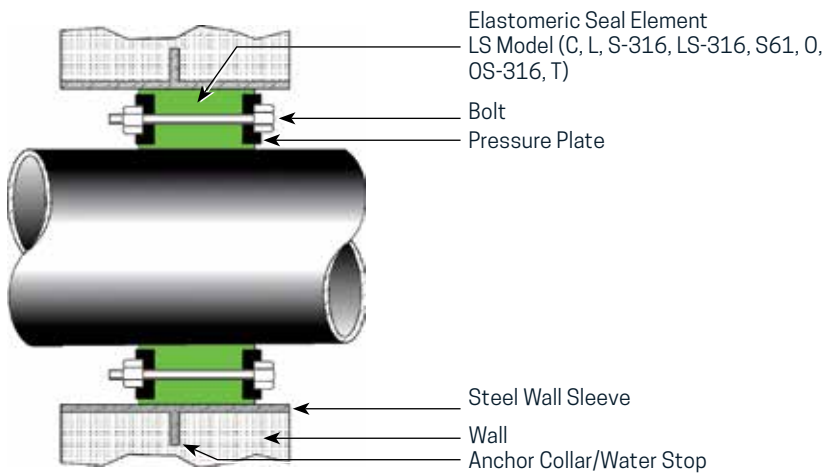

LINK-SEAL® Model No. Example

LS - 400 - C - 10

LINK-SEAL® _____
 Size _____
 Model _____
 No. of Links _____

Steel WS Sleeve Model No. Example

WS - 14 - 25 - S - 12

Wall Sleeve _____
 Sleeve Nominal _____
 Steel Wall Thickness _____
 Steel _____
 Length in Inches _____

LINK-SEAL® MODULAR SEALS WITH CAST, CORE DRILLED OR CELL-CAST® DISK WALL OPENING

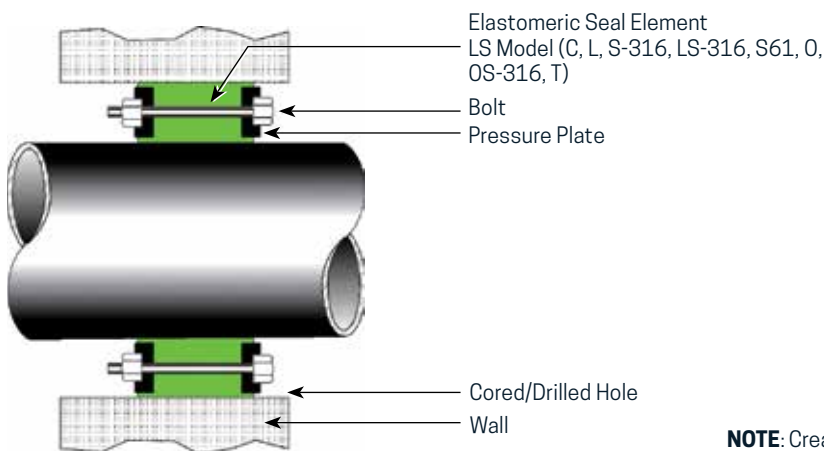

LINK-SEAL® Model No. Example

LS - 400 - C - 10

LINK-SEAL® _____
 Size _____
 Model _____
 No. of Links _____

CELL-CAST® Disk Model No. Example

CC - 30 - (3)2 - (4)2

CELL-CAST® _____
 No. 3" Disks _____
 No. 4" Disks _____

NOTE: Creating a 30" (29.25" I.D.) Hole with a 14" Wall Thickness. Specify TRA at the end of the ordering code for threaded rod assembly.

*CAD (.dwg) drawings are available online @ www.gptindustries.com

Typical Specification

1.0 GENERAL

Under this section a complete LINK-SEAL® modular seal assembly as shown on drawings and specifications, manufactured by GPT located at 6455 Clara Road Houston Texas 77041 will be furnished and installed. For clarification, complete assembly is defined as a combined:

- A. Wall (Floor, Ceiling) opening (i.e. steel sleeve, Thermoplastic (HDPE) sleeve, cored hole or formed hole). The wall opening size and/or type must be selected according to information found in the most recent LINK-SEAL® modular seal catalog.
- B. Sufficient quantity and type of LINK-SEAL® modular seals required to effectively provide a hydrostatic and/or fire-rated seal.
- C. Each individual link must be conspicuously and permanently identified with the name of the manufacturer and model number. Manufacturers other than GPT® wishing to quote equipment in this section must submit detail drawings of their proposed equipment and suitable evidence of a minimum of 25 years of experience and results to the engineer to obtain written approval to quote at least ten (10) days prior to bid opening.

2.0 LINK-SEAL® MODULAR SEAL RUBBER LINKS

Must be modular, mechanical type, consisting of interlocking synthetic rubber links shaped to continuously fill the annular space between the pipe and the wall opening. The elastomeric element must be sized and selected per manufacturer's sizing procedure and have the following properties as designated by ASTM. Coloration must be throughout elastomer for positive field inspection. Each link must have a permanent identification of the size and manufacturer's name molded into it.

- A. Standard Service Applications = Model C
-40 to +250°F (-40 to +121°C)
EPDM = ATSM D2000 M3 BA510 Color = **Black**
- B. Potable Water/NSF 61 Service Applications = Model S61
-40 to +250°F (-40 to +121°C)
EPDM = ATSM D2000 M3 BA510 Color = **Black**
- C. Thin Walled Pipe Applications = Model L
-40 to +250°F (-40 to +121°C)
EPDM = ATSM D2000 M3 BA510 Color = **Blue**
- D. Hydrocarbon Service Applications = Model O
-40 to +210°F (-40 to +99°C)
Nitrile = ASTM D2000 M1BF510 Color = **Green**
- E. High Temperature or Fire Seal Applications = Model T
-67 to +400°F (-55 to +204°C)
Silicone = ASTM D2000 M1GE505 Color = **Gray**

Reference must always be made to the latest published LINK-SEAL® modular seal selection guide for the service intended.

2.1 LINK-SEAL® MODULAR SEAL PRESSURE PLATES

- A. LINK-SEAL® modular seal pressure plates must be a uniform pressure plate design molded of glass reinforced Nylon Polymer with the following properties:
Izod Impact - Notched = 2.05ft-lb/in. per ASTM D-256
Flexural Strength @ Yield = 30,750 psi per ASTM D-790
Flexural Modulus = 1,124,000 psi per ASTM D-790
Elongation Break = 11.07% per ASTM D-638
Specific Gravity = 1.38 per ASTM D-792

- B. Models LS200-275-300-315 must incorporate the most current LINK-SEAL® Modular Seal design modifications and include an integrally molded compression assist boss on the top (bolt entry side) of the pressure plate, which permits increased compressive loading of the rubber sealing element. Models 325-340-360-400-410-425-475-500-525-575-615 must incorporate an integral recess known as a "Hex Nut Interlock" designed to accommodate commercially available fasteners to insure proper thread engagement for the class and service of metal hardware. All pressure plates must have a permanent identification of the manufacturer's name molded into it.
- C. For fire and hi-temp service, pressure plates must be steel with 2-part Zinc Dichromate Coating.

2.2 LINK-SEAL® MODULAR SEAL HARDWARE

All fasteners must be sized according to latest LINK-SEAL® modular seal technical data. Bolts, allen head/flange hex nuts must be either:

- A. Mild Steel with a 60,000 psi minimum tensile strength and 2-part Zinc Dichromate coating per ASTM B-633 and Organic Coating, tested in accordance with ASTM B-117 to pass a 1,470 hour salt spray test.
- B. 316 Stainless Steel per ASTM F593-95, with a 85,000 psi average tensile strength.

3.0 WALL OPENING

- A. CENTURY-LINE® Sleeves - for openings to 24.75" diameter. Where pipes must pass through walls and floors of new structures, unless otherwise shown or specified, install molded non-metallic high density polyethylene Model CS CENTURY-LINE® sleeves as manufactured by GPT. Model CS sleeves must have integrally formed hollow water stop sized having a minimum of four inches larger than the outside diameter of the sleeve itself and allowing 1/2" movement between wall forms to resist pour forces. Each sleeve assembly must have end caps manufactured of the same material as the sleeve itself and installed at each end of the sleeve so as to prevent deformation during the initial concrete pour, and to facilitate attaching the sleeve to the wall forms. End caps must remain in place to protect the opening from residual debris and rodent entry prior to pipe insertion.
- B. CELL-CAST® Disks - for openings from 29.25" to 64.74" diameter. The contractor must install CELL-CAST® disks, providing a round hole in conformance with LINK-SEAL® modular seal sizing data. CELL-CAST® disks must consist of 3" and/or 4" lightweight interlocking polyethylene cells stacked to form the thickness of the poured concrete wall. Molded into each cell must be a cavity to accept a 2" x 4" nailer.

4.0 QUALITY ASSURANCE

LINK-SEAL® Modular Seal components and systems will be domestically manufactured at a plant with a current ISO 9001:2008 registration. A copy of ISO 9001:2008 registrations will be a submittal item.

NOTE: LINK-SEAL® Modular Seals are specifically designed as hydrostatic and/or fire rated seals and are not considered to be pipe supports. When appropriate, LINK-SEAL® Modular Seals should be used with proper pipe supports on both ends.



Frequently Asked Questions

1Q - Can LINK-SEAL® modular seals be used with pipe types not listed in the standard published charts?

1A - Yes, The best way to permanently seal any cylindrical object, of any size, passing through any type of concrete barrier is to use LINK-SEAL® modular seals. From ductile iron to pre-stressed concrete to metal or plastic pipe, conduit or cables - whatever your application - LINK-SEAL® modular seals will effect a hydrostatic seal capable of holding 20 psig (40 feet of static head) between the pipe and the penetration cylinder through which the pipe passes.

2Q - How much angular pipe movement will LINK-SEAL® modular seals allow and still maintain a seal?

2A - LINK-SEAL® modular seals may allow angular pipe movement or misalignment depending on the ratio of annular space of the penetration to the expanded range of the LINK-SEAL® model sized for the penetration. Please call GPT® for more information.

3Q - When is the recommended time to install LINK-SEAL® modular seals?

3A - Always install LINK-SEAL® modular seals prior to final connections and back filling. This helps prevent off-center pipe alignment.

4Q - Is it necessary to use WS or CS sleeves when installing LINK-SEAL® modular seals?

4A - WS model steel and CS model HDPE sleeves are specially designed for use with LINK-SEAL® modular seals and are an ideal combination for new pours. When installed with LINK-SEAL® modular seals these will provide the best possible assurance of a quality wall penetration system.

5Q - What tools are required to install LINK-SEAL® modular seals?

LINK-SEAL® Model	Tool Size/Type Req.
LS-200, LS 275	4mm, Allen
LS-300, LS-315	6mm, Allen
LS-325, LS-340, LS-360	13mm, Hex
LS-400, LS-410, LS-425, LS-475	17mm, Hex
LS-500, LS-525, LS-575	19mm, Hex
LS-615	30mm, Hex
LS-650	19mm, Hex

5A - Set of ratchet tools (with extensions if needed). If installing Carbon Steel hardware a low speed (450 RPM or less) power tool can be used for multiple installations to increase efficiency.

6Q - Can I use power tools when installing LINK-SEAL® modular seals with 316 stainless steel bolts?

6A - No, please refer to suggested installation techniques.

7Q - Sometimes when installing a LINK-SEAL® modular seal belt, it hangs loose on the pipe even though all my sizing calculations are correct. Why does it appear that I have too many links?

7A - LINK-SEAL® modular seals are sized to fit the annular space, not the pipe. It is important to not remove links. Use the assemblies suggested by the charts or calculation. It may not look right, but it will fit.

8Q - Can LINK-SEAL® modular seals be used for penetrations where the pipe is off-center to the opening?

8A - Centering is very important to achieve a tight seal with LINK-SEAL® modular seals. Contact your local stocking distributor or GPT® for center solutions or availability of seals for off centered applications.

9Q - How do I install LINK-SEAL® modular seals over a weld-bead?

9A - Weld-beads and all other irregularities on the pipe or opening should be addressed in accordance with the manufacturer's and/or project engineer's suggestions to provide a round, smooth and clean surface for LINK-SEAL® installation.

10Q - My wall is 24" thick. Do I need LINK-SEAL® modular seals on both sides of the wall?

10A - In many cases, one single LINK-SEAL® modular seal assembly is appropriate. Double seals are typically found in critical applications such as fire walls or nuclear power stations. Double seals are also suggested for building foundation wall penetrations where the wall thickness is greater than 16".

11Q - Can LINK-SEAL® modular seals be used with manhole vault installed thimbles, not sleeves?

11A - No, only if the area creates a penetration cylinder, such that the axis of the cylinder is parallel to the axis of the pipe going through it.

12Q - Can lubricant be used to install LINK-SEAL® modular seals?

12A - Yes, any non-polluting liquid detergent is preferred over a grease. If you need to use grease or another lubricant, please contact GPT®.

13Q - Should you grout over LINK-SEAL® modular seals?

13A - LINK-SEAL® modular seals do not require any assistance to create a water tight seal, if they are installed per our published installation techniques. Any material placed between the seal and the ID of the penetration is not recommended. However, if grout is needed for appearance purposes only, it's suggested that the links be installed far enough into the penetration to accommodate a layer of "bubble wrap". If the pipe needs future maintenance the grout can be removed and access can be gained to the bolts of the LINK-SEAL® modular seal.

Frequently Asked Questions

14Q - What model LINK-SEAL® modular seals should be used for submerged sea water applications?

14A- For submerged sea water applications use Model S-316 LINK-SEAL® modular seals. See pages 6 & 7 for material property information.

15Q - Why is it sometimes difficult to seal an insulated pipe with LINK-SEAL® modular seals?

15A - Jacket thickness, or more importantly, its ability to maintain its diameter without deforming is key to success of the LINK-SEAL® modular seal's ability to seal. If the jacket withstands the constricting force of the LINK-SEAL® modular seal without cracking or deforming, LINK-SEAL® modular seals are effective. If the jacket "gives", much like an aluminum can, the jacket will crack enabling water to go directly into the insulation and by pass the LINK-SEAL® modular seal installation.

16Q - What is the life expectancy of LINK-SEAL® Products?

16A. - GPT® does not list a life expectancy on LINK-SEAL® Modular Seal due to the varied applications they are used in. GPT® LINK-SEAL® modular seals have been in service for in excess of 40 years, although too many variables are present to accurately apply a specific life expectancy value.

17Q When should the CB model LINK-SEAL® be used?

17A - CB model LINK-SEAL® are suggested with larger pipes. Typically installed in pipeline casings, their primary function is to provide temporary support while tightening LINK-SEAL®

18Q - Is it necessary to use riser clamps, pipe saddles and hanger supports with LINK-SEAL® modular seals?

18A - LINK-SEAL® modular seals are penetration type seals. It is not intended to be a structural support. Standard pipe hanger practice should always be applied.

19Q - Why are torque values not used to install LINK-SEAL® Modular Seals?

19A - Every penetration has unique parameters; OD, ID, surface smoothness, ratios of annular space to expanded range. Follow Step #6 in the Published Installation Techniques for proper installation.

20Q - Do you recommend the LINK-SEAL® modular seals be installed in the back, middle or front of a penetration?

20A - It is better to install the LINK-SEAL® modular seals so that it is easy to access the bolt heads in case the LINK-SEAL® need to be adjusted at any time in the future. This also makes the initial installation easier.

21Q - Should wall sleeves be installed in an existing wall prior to LINK-SEAL® modular seals?

21A - Sleeves without weep rings will not provide water tight penetrations. GPT® does not recommend retrofitting a wall sleeve for existing concrete wall applications.

22Q - When should Low Durometer EPDM Model L or L-S316 be used vs Standard EPDM Model C or S316?

22A - It is suggested to use the Low Durometer EPDM Model L or L-S316 for soft walled pipes (Tubing PE, PVC and HDPE) with a wall thickness less than 3/8".

23Q - When should Model S61 NSF-61 certified LINK-SEAL® modular seals be chosen over standard EPDM Model S316?

23A - Any time that potable water will come in direct contact with LINK-SEAL® modular seals (i.e. penetrating fill tank, pump station, etc).



LINK-SEAL® Modular Seal Technical Approvals

The following is a partial listing of the many Federal agencies, associations, code groups, laboratories and organizations which have approved, listed, specified, tested or otherwise indicated acceptance of LINK-SEAL® modular seals.

GENERAL CODE GROUPS, ASSOCIATIONS, LABORATORIES AND APPROVAL AUTHORITIES

- AWWA - American Water Works Association
- AIS - American Iron and Steel
- API - American Petroleum Institute
- ASME - American Society of Mechanical Engineers
- Bureau Veritas - Marine Division
- DNV - Det Norske Veritas
- FM - Factory Mutual Engineering Corporation
- LLOYD'S - Lloyd's Register of Shipping
- NACE - National Association of Corrosion Engineers
- NSF/ANSI 61 - Drinking Water System Components
- TÜV - Technischer Überwachungs-Verein

GOVERNMENT AGENCIES

- Bureau of Public Roads - Division of Bridges
- United States Coast Guard
- Corps. of Engineers
- GSA - General Services Administration
- Military Specifications
- TVA - Tennessee Valley Authority
- ARRA - American Recovery Reinvestment Act

CALLING-OUT THE ORIGINAL LINK-SEAL® MODULAR SEAL SYSTEM



Approvals:	ISO 9001:2008, Factory Mutual, NSF 61
Elastomers:	EPDM, Nitrile, Silicone
Made in America (U.S.A.)	Yes
Permanent Identification	Yes
Corrosion Resistant Fasteners 316 Stainless as Standard	Yes
16 Model Sizes	Yes
Hi/Low Temp. Seals	Yes
FM Approved Fire Seals, NSF 61 Certified	Yes
Bolts available in Metric Format	Yes
Bolts pass 1470 hour salt spray test	Yes
Non-conductive CS Molded Sleeve Penetration System	Yes
Low torque Pressure Plate and Elastomer	Yes
Special "V" Modification Pressure Monitoring	Yes
Color Coded Elastomers and Pressure Plates	Yes
CELL-CAST® Hole Forms	Yes
On Staff Seal Engineering Assistance	Yes
Worldwide Stocking Distributors	Yes
Bolt and Nut Specifications per ASTM Standards	Yes
Universal Pressure Plate Design	Yes
(See LINK-SEAL® Modular Seal specification, section 2.2, page 37)	



WARRANTY AND CONDITION OF SALE

The seller warrants that all goods furnished under this order will be free from defects in material and workmanship and will conform to GPT® published specifications.

The limit of GPT's liability for failure of any of our products to meet the foregoing warranty, or for breach of any other warranty, express, implied or statutory, shall be to supply an equivalent amount of product for any materials returned to us within 12 months of shipment and found to be defective by GPT®.

Due to the widely varying conditions under which our products are used or installed, GPT® offers no warranty as to their merchantability, length of service or suitability for any particular purpose, express or implied, other than described above.

The Purchaser accepts full responsibility for installation of all goods furnished under this order and for any defects or damage suffered as a result of defective installation of such goods. No instructions, advice, or aid relative to installation given by the Seller to the Purchaser shall be construed as a warranty as to the accuracy or utility of such instructions, advice, or aid, but only as an accommodation to the Purchaser and an opinion of the Seller.

The foregoing conditions of sale shall not be modified or affected in any way whatsoever by reason of Seller's receipt or acknowledgement of Buyer's purchase order or any other related instrument of paper containing additional or different conditions and, to the extent there may be any terms or provisions in such a purchase order, etc., which may be in conflict with or modification of the foregoing, such terms and provisions of such purchase order, etc., shall be deemed to have no force or effect.



GPT 1:8 | 02.2017



www.gptindustries.com

4990 Iris Street
Wheat Ridge, CO 80033
Tel: (303) 988-1242
Fax: (303) 988-1922

6455 Clara Road, Suite 300
Houston, TX 77041
Tel: (713) 747-6948
Fax: (713) 747-6029

2 Woodlands Sector 1
#03-11 Woodlands Spectrum 1
Singapore 738068
Republic of Singapore

Unit 3-5, Chester Road
Colmworth Business Park
Eaton Socon, St. Neots
Cambridgeshire, PE 19 8YT

Oilfields Supply Center Ltd.
Executive Office 4,
PO Box 1518
Jebel Ali Free Zone, Dubai
United Arab Emirates